

# **VASTEX**

## **SCREEN PRINTING EQUIPMENT**

### **DiGiT Numbering System**

Models: V2NS-8 & V2NS-12

Assembly and Operating Manual

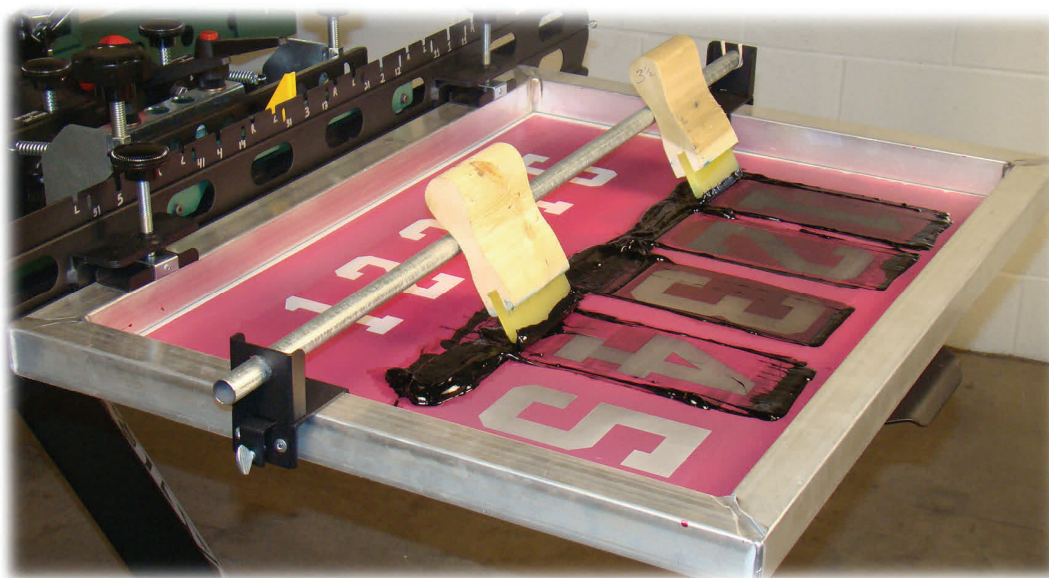

This manual contains the following documents:

- Page 2 Introduction / Component ID / Attachment Installation**
- 3 Site & Detent Rail Installation **\*\*IMPORTANT\*\*****
- 4 Site Rail and Number Alignment Overview**
- 5 Alignment Instructions & Tips**
- 6 Operating Instructions & Adjustments**
- Alignment Guide**

#### **Vastex E-mail assistance**

Purchasing & Product Info:  
[sales@vastex.com](mailto:sales@vastex.com)

Electrical Support:  
[stech@vastex.com](mailto:stech@vastex.com)

Tech Support, Mechanical Setup, and Operation  
[techsupport@vastex.com](mailto:techsupport@vastex.com)

Screen Printing Issues & Support:  
[printech@vastex.com](mailto:printech@vastex.com)

Vastex International, Inc.  
7 Emery St  
Bethlehem, Pa. 18015 USA  
Phone# 610 625-2702 Fax# 610 625-2775  
Web Site [www.vastex.com](http://www.vastex.com)

# Introduction

The DiGiT was designed and built as light as possible, while still maintaining great strength and durability. This attachment will clamp into any rear clamp manual press. The print head must be able to support a minimum of 25 lbs for the 8" attachment and 30 lbs for the 12" attachment. It must also be strong enough to hold the screen level when slid to the end printing positions. Additional springs or shocks may be required for your press to hold this attachment. **Vastex is not responsible for damages incurred while trying to retrofit our DiGiT to your press.** A Vastex V-2000 press only needs a double gas spring instead of the standard single gas spring to hold up the DiGiT. V-1000 owners must upgrade to (optional) HD head.

There are different Site and Detent Rails for all sizes of numbers. The same Site and Detent rails are used for either screen of the same height numbers. Detent Rails are marked at the factory with the number height. The Site Rails are labeled from the factory as shown on **page 3** of this manual.

# Component ID

Parts included in each attachment box.

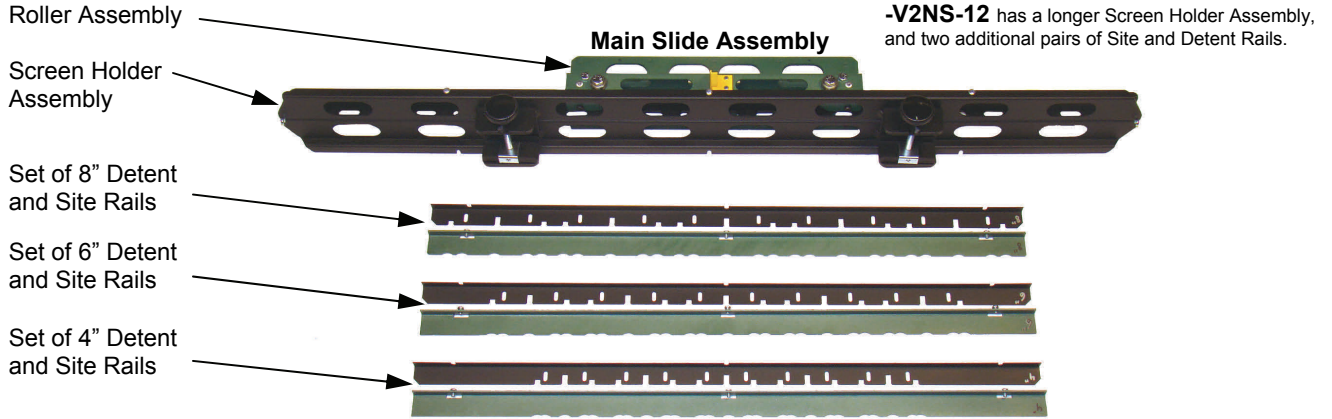

# Attachment Installation

- 1) Lower the print head
- 2) Slide the pallet at least 5" away from the clamps. (shown on right)
- 3) Place the Main Slide Assembly into the screen clamp. Be sure it is centered, then tighten the rear clamps.
- 4) Install lift springs to support the extra weight. **V-2000 owners:** Install included double gas spring as shown below.
- 5) Install second assembly and verify there is no inter-ferece between the two assemblies.
- 6) Set the off contact to 3/8"

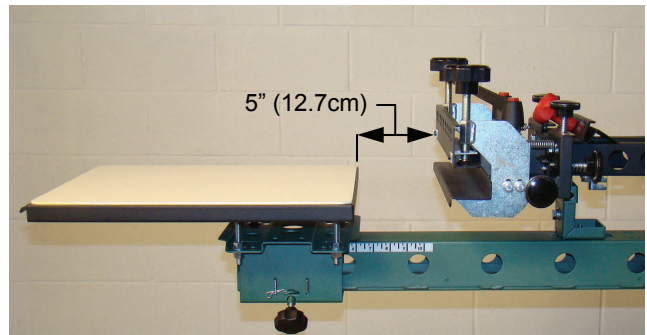

**Note**

Be sure the Roller Assembly is centered and as far back in the clamps as possible. Install the Roller Assembly parallel to the rear clamps.

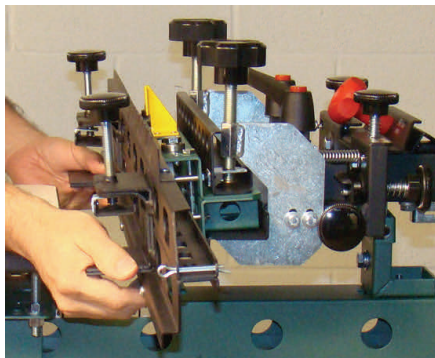

Numbering Attachment being installed

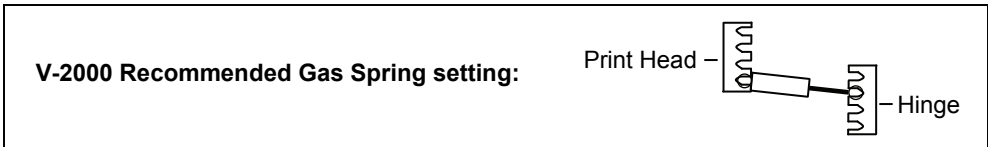

## Site Rail Installation

The Site Rail is a visual aid for selecting the desired print location of the numbers.

- 1) Loosen the three phillips head screws circled in the picture below.
  - 2) Slide the Site Rail under the screw heads and tighten.
- Be sure to install the correct Site and Detent Rails to match the screen you will be using.**

### Note

The Site and Detent Rails can be installed while the numbering attachment is installed on the press. This is shown off the press for instructional purposes only.

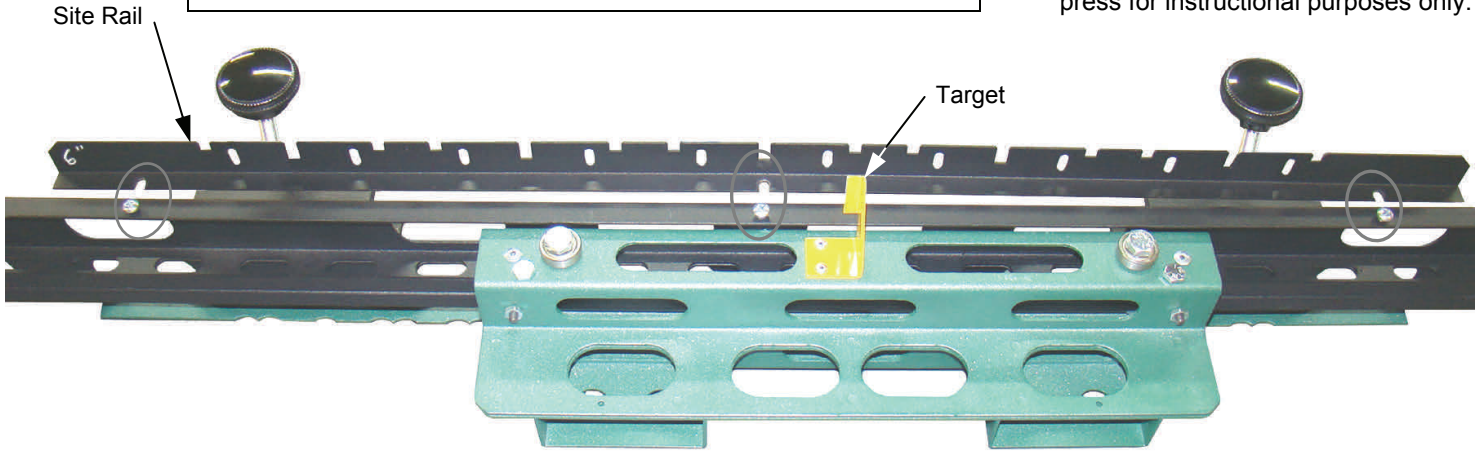

- 3) Site Rails should be labeled from the factory as shown below.

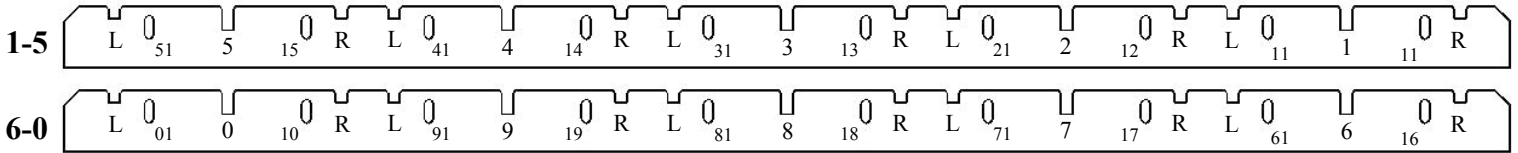

## Detent Rail Installation

The Detent Rail controls the location of the number. Five positions are available for each number. This is a very important step.

- 1) Loosen the three phillips head screws on the Detent Rail. (shown below) (V2NS-12 has 5 screws to install Detent Rail).
  - 2) Slide the Detent Rail onto the bottom of the Numbering Attachment and tighten them down well. See photo (bottom right) for visual reference.
- Be sure to install the correct Site and Detent Rails to match the screen you will be using.**

### Important!

Detent rails must be installed as shown below. Be sure grooves in rail lock into the roller bearing!

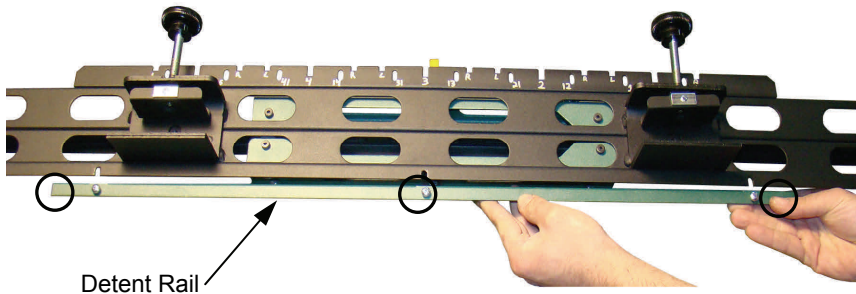

The grooves in the Detent Rail engage into a Roller Bearing, locking the screen into position.

Roller Bearing

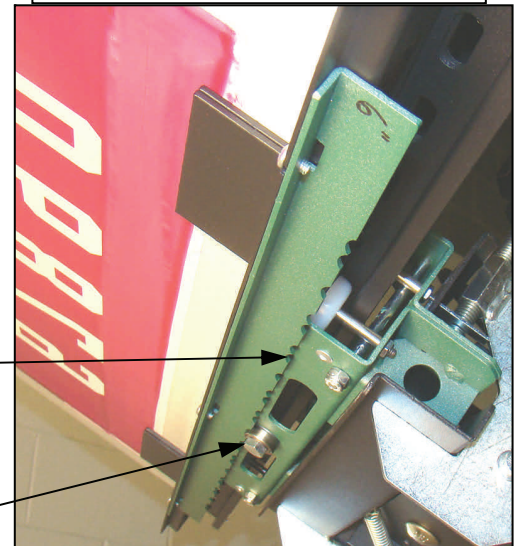

(The picture above shows the correct orientation of an installed Detent Rail.)



# Site Rail and Number Alignment Overview

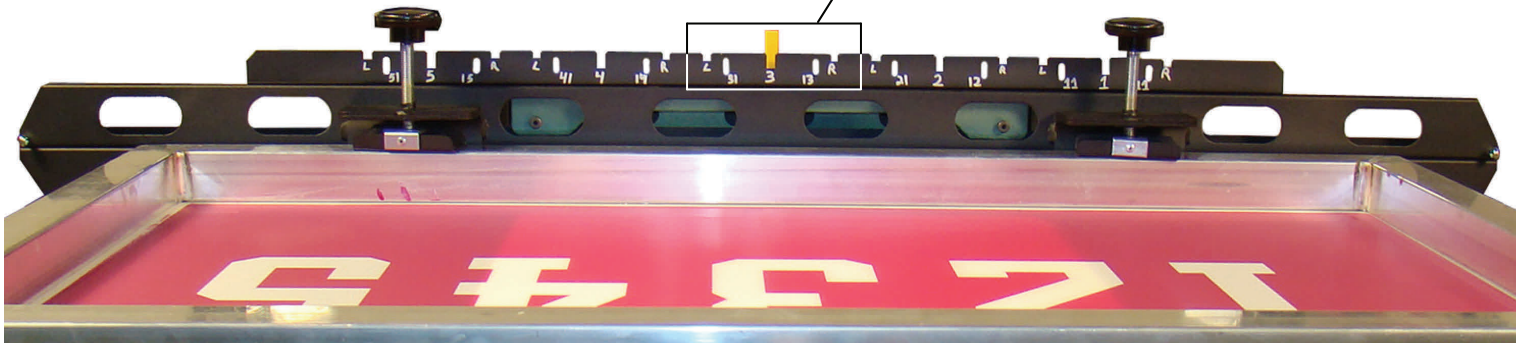
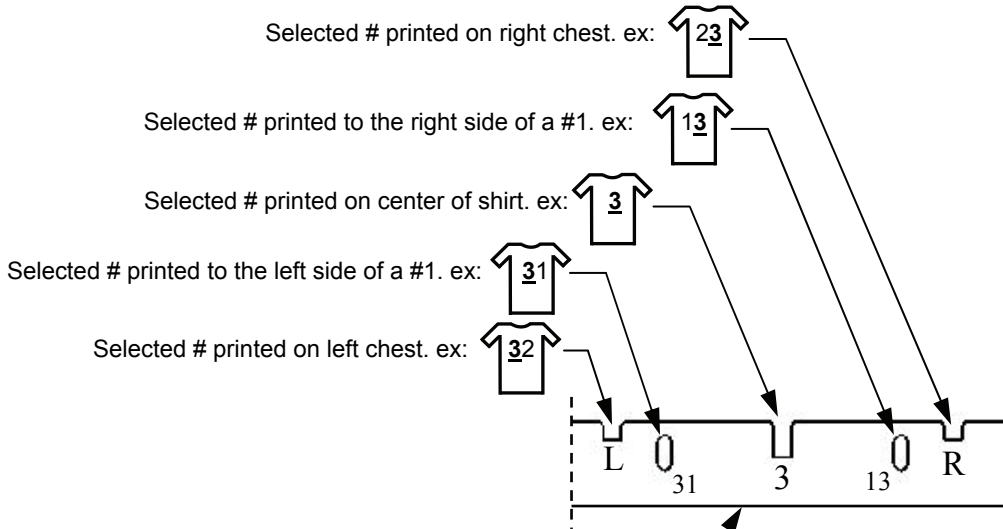

Example prints with their Site Rail locations for printing

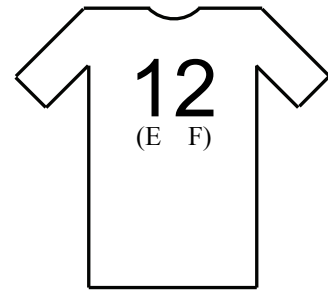
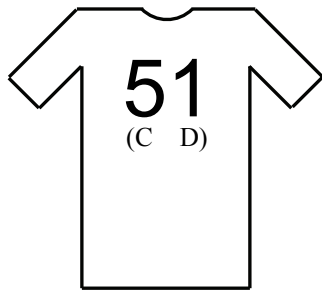
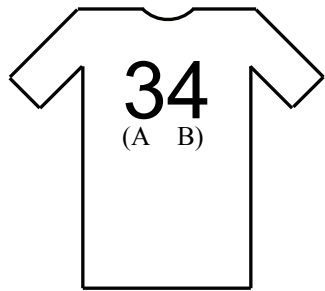

(Letters shown on shirts are for Site Rail references only.)

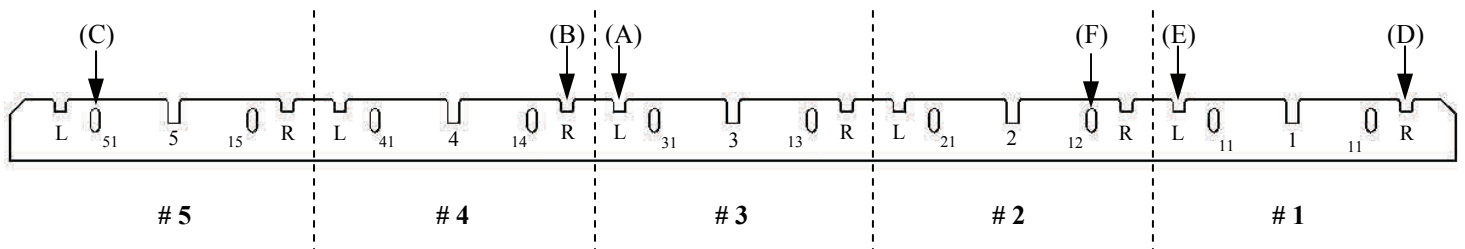

# Alignment Instructions & Tips

To align your DiGiT Numbering System, please photocopy the Alignment Guide (AG) which is the back page of this manual. This page will aid you in aligning your screens.

1) Photocopy (full size) back page of DiGiT Manual. (AG)

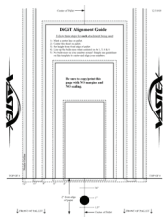

2) Position and attach the AG on the pallet using a center line and references found on the AG.

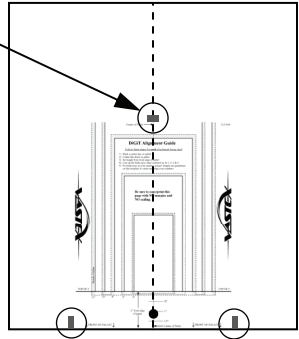

3) Lower the screen and slide the attachment to the center position of the number farthest to the left.  
4) Line up and center the round Alignment Mark on the AG to the oblong Alignment Mark on the screen.

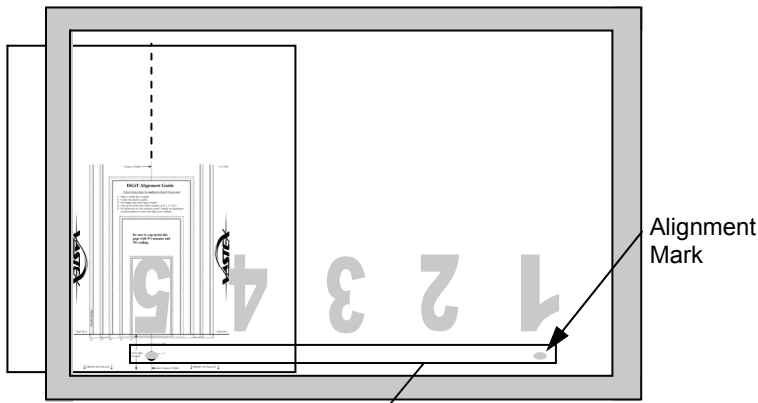

5) Slide the screen to the center position of the number farthest to the right.  
6) Repeat step 4

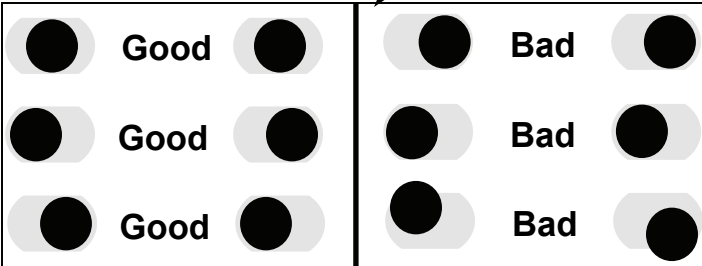
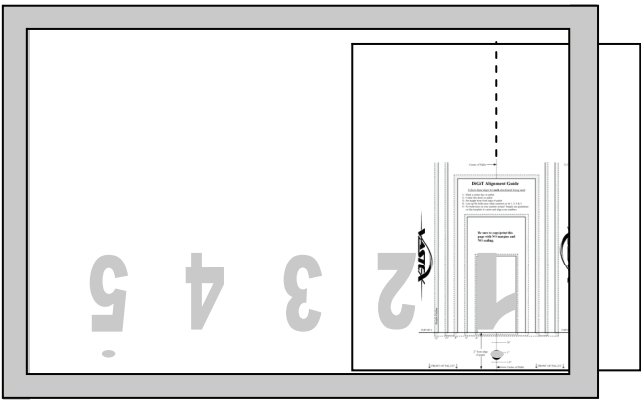

7) After you have the Alignment Marks lined up on each screen you are printing with, print a test print. For single color printing, the Alignment Marks will adequately register your job. For two color printing, additional registration may be necessary to equalize the amount of Trap on all sides.

If your screens do not have, or you do not want to use, the Alignment Marks, you can do the same procedure with the box outlines on the AG.

"Trap" is the amount of overlap between the solid and outline of a number.

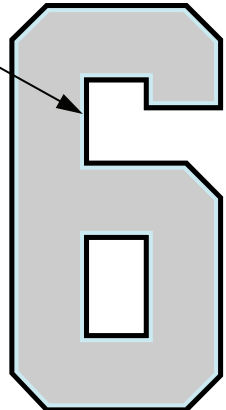

For best results; Print both digit's solid color, flash, and then print the outline. It is easiest to achieve a uniform outline thickness with this procedure.

# Operating Instructions

- 1) Install the DiGiT numbering attachments.
- 2) Install required Site and Detent Rails.
- 3) Clamp in and locate screen.
- 4) Be sure your screen is leveled in both directions. Set off contact to 3/8" to ensure the screen locks fully into the Detent Rail.
- 5) Install (optional) Vastex Squeegee Rest onto screen.
- 6) Ink the screens with athletic ink. For athletic numbering tips, see document (01-08-028) found at Vastex.com or contact Vastex Sales department.
- 7) Use squeegees cut to proper width. See chart for sizes.
- 8) Tilt the screen slightly to slide to the required number. Print position and sliding position are shown below.
- 9) Each number has five printing positions. (Pg 3) Align the Site Rail to the Target for the desired printing location. When the screen is in the print position, the detent will engage into the roller bearing. A properly set off contact is required for this to function correctly.
- 10) For printing two color numbers, rotate the pallet under the flash then proceed with the outline or drop shadow.
- 11) To raise the print head, center the screen and gently lift.
- 12) Do not lean on number screens. Damage to the mechanism can occur and off contact will suffer.

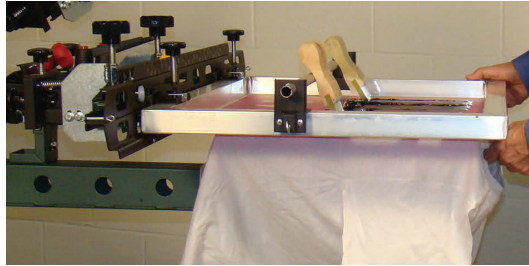

Print position (shown above)

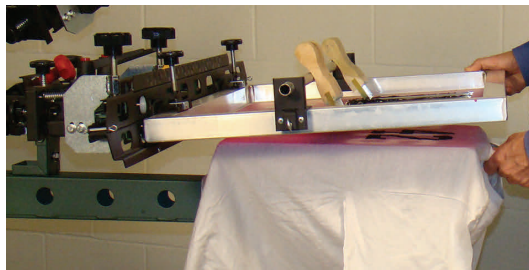

Sliding position (shown above)

Recommended Squeegee width					
2"	2-0	1 1/2"	8"	2-0	5"
	1	1 1/4"		1	3 1/2"
4"	2-0	2 3/4"	10"	2-0	5 3/4"
	1	2"		1	3 3/4"
6"	2-0	3 3/4"	12"	2-0	7"
	1	2 3/4"		1	4 1/4"

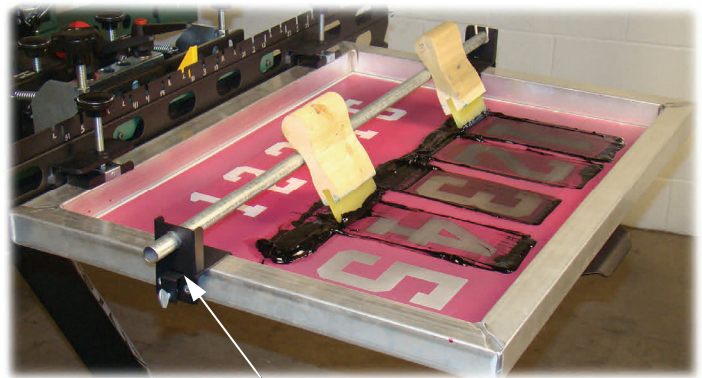

(Optional) Vastex Squeegee Rest

## Adjustments

The spacing between the rollers, in the Roller Assembly, have been preset at the factory. It may be necessary to make a slight adjustment to the roller spacing as the rollers wear. If the screen does not maintain level when the screen is slid to the end positions, the rollers may need to be adjusted. With the print head lowered, center the Screen Holder Assembly in the Roller Assembly. While holding down firmly on the print head, lift up and down on the Screen Holder Assembly. There should be no noticeable vertical movement between the rollers and the Screen Holder Assembly. If movement is noticed, use two 7/16 wrenches to tighten the adjustment bolt. Tighten no more than 1/8 turn at a time. Recheck for vertical movement. Do NOT over tighten!! Adjust both sets of rollers. If the rollers are adjusted too tight it will be difficult to slide the Screen Holder Assembly.

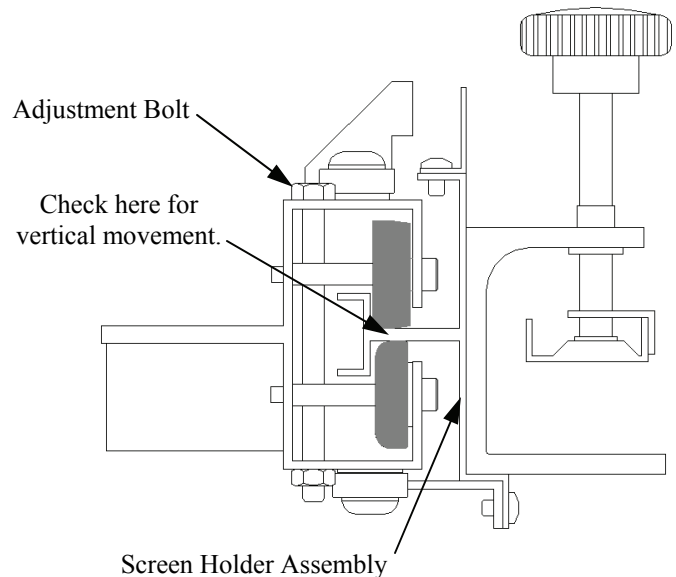

NOT NEEDED ON V2000 PRESS

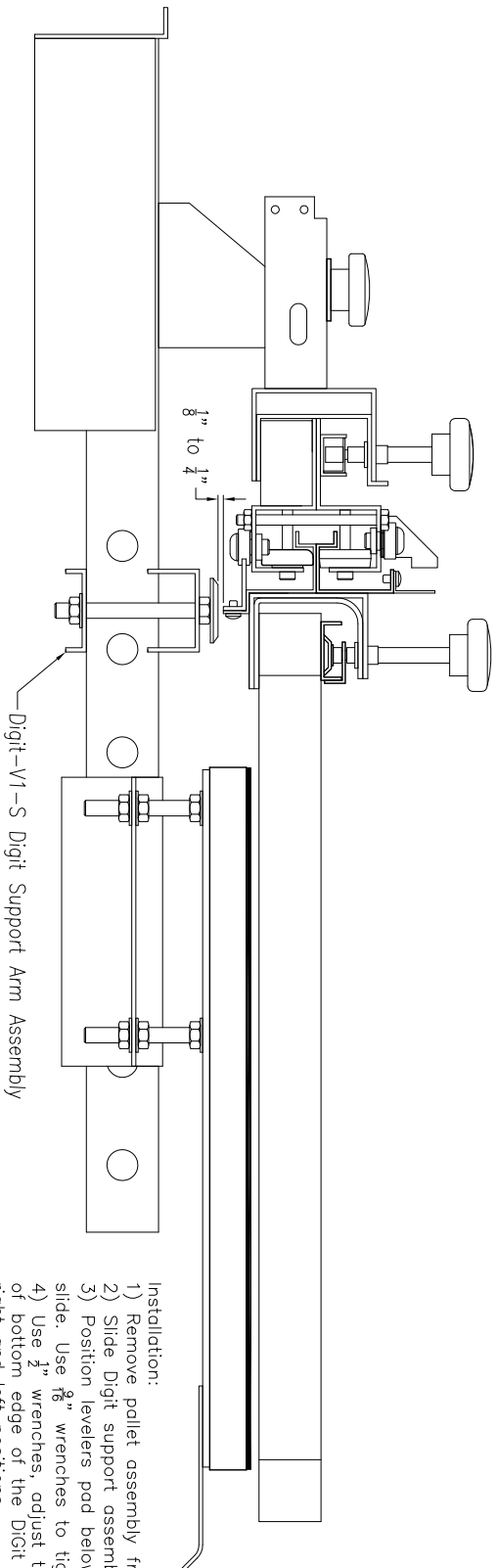

- Installation:
- 1) Remove pallet assembly from rotor arm.
  - 2) Slide Digit support assembly onto rotor arm.
  - 3) Position levelers pad below the bottom edge of the Digit slide. Use  $\frac{9}{16}$ " wrenches to tighten bolts, do not over tighten.
  - 4) Use  $\frac{1}{2}$ " wrenches, adjust the leveler pods to within  $\frac{1}{8}$ " to  $\frac{1}{4}$ " of bottom edge of the Digit slide assembly when in the full right and left positions.
  - 5) Reinstall pallet assembly.

Note: Leveler pods are only for the slightest support of the Digit slide when in the full right and left positions. If adjusted to close to bottom edge of the slide, registration will be affected.

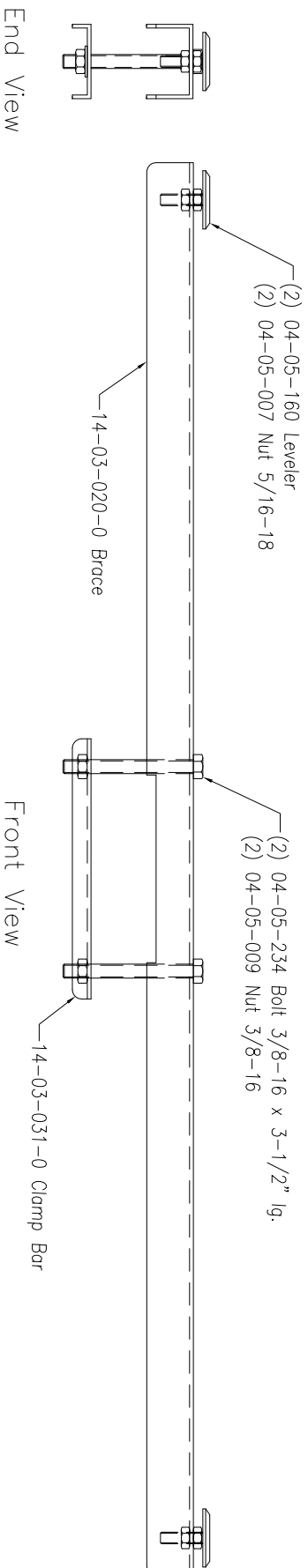

End View

Front View

<b>GENERAL ENGINEERING</b> <b>MANUFACTURING</b> <b>SINCE 1950</b> <b>VASTEX.COM</b>		TOLERANCES UNLESS OTHERWISE SPECIFIED		<b>VASTEX INTERNATIONAL</b>	
DECIMAL FRACTION ANGLE	.XXX XX X	±.010 ±.015 ±.032	±.1 ±.16	TITLE: DIGIT SUPPORT ARM DIGIT-8 & DIGIT-12 V-1000 PRINTER	SCALE: none
DRAWN CHECKED APPROVED	BY DATE	DATE	FRACTION ANGLE	SIZE DRAWING NO.	SHEET 1 OF 1
C/D M/J/11	M/J/11	M/J/11	±.1 125°	C 01-19-004	REV# -

Center of Pallet →

# DiGiT Alignment Guide

Follow these steps for each attachment being used

- 1) Mark a center line on pallet.
- 2) Center this sheet on pallet.
- 3) Set height from front edge of pallet.
- 4) Line up the Alignment Marks when centered on #s 1, 5, 6 & 0
- 5) No bulls-eyes on your number screen? Simply use guidelines on this template to center and align your numbers.

Be sure to copy/print this page with NO margins and NO scaling.



Number Outline

TOP OF #

TOP OF #

12" 10" 8" 6" 4"

1/2"

2" from edge of paper

1"

Alignment Mark

1.5"

↓ FRONT OF PALLET ↓

← Center of Pallet

↓ FRONT OF PALLET ↓