

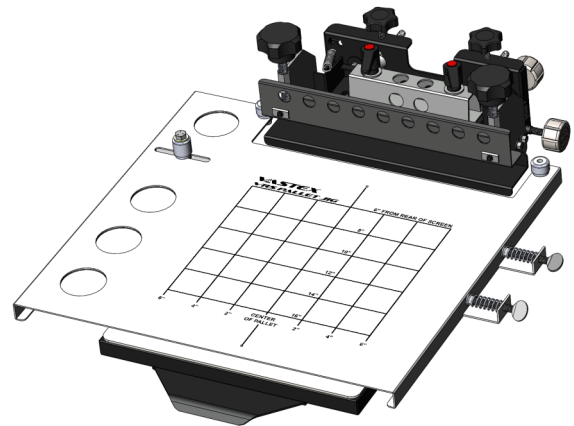

Vastex Manual Press Registration System Assembly and Operations Manual

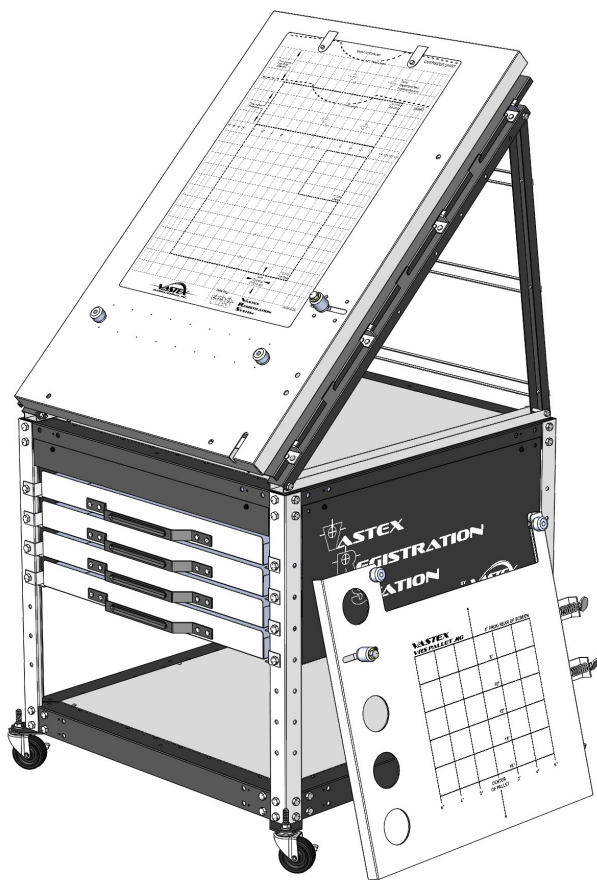

Contents

	Pg. #
Introduction	2
Component Identification	2-3
Pallet Jig Assembly (Manual Rear Clamp)	4
Pallet Jig Assembly (Manual Side Clamp)	5
Pin Board Assembly	6
Operation	7-10

Vastex International, Inc.
7 Emery Street
Bethlehem, PA 18015
Phone# 610 625-2702
Fax# 610 625-2775
Web Site: www.vastex.com
E-Mail: info@vastex.com

Introduction

Thank you for purchasing a Vastex VRS System. Vastex has been designing and building printing equipment since 1960. We have knowledge and experience, and are proud to supply the printing industry with quality equipment at an affordable price. You can be confident your purchase will give you years of trouble free service.

Registrations systems are a method for accurately locating art work onto screens and into your printer. VRS systems are available for manual and automatic presses. This manual covers the setup and operation of your registration system.

Tools Required

- 9/16" wrench
- 7/16" wrench
- 1/4" Nut Driver
- Roll of Double Sided Tape (Operation method 1)

Component ID

Illustrations of components within this manual may be shown different than your actual components.

1

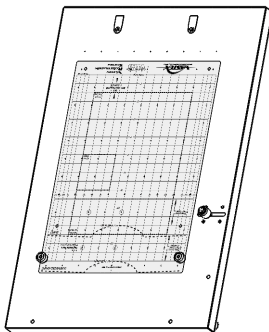

Side Clamp Version

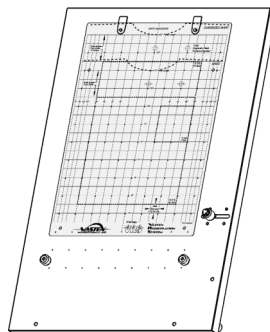

Rear Clamp Version

- 1) The **Pin Board** is designed to be used with many different exposing units. The two most popular versions are shown on the left. The VRS Pin Board has a placement grid attached to the face. Your specific pin board may be different than those shown.

2

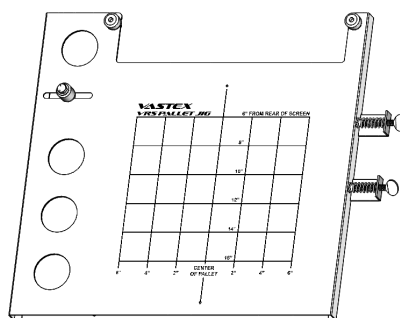
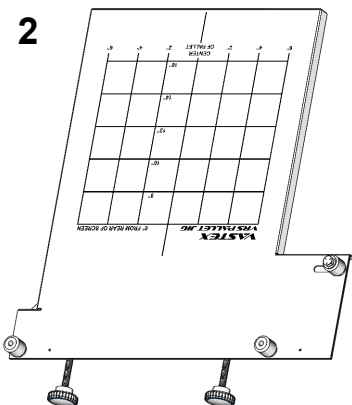

- 2) The **Pallet Jig** is used to accurately position exposed screens onto your press.

Component ID (cont'd)

3



- 3) Optional **Pin Board Stand** is used to support your pin board at a comfortable angle. The pin board stand is available with fixed levelers or with locking casters. (PRE-06/2018)

Assembly Doc: 01-13-006

4

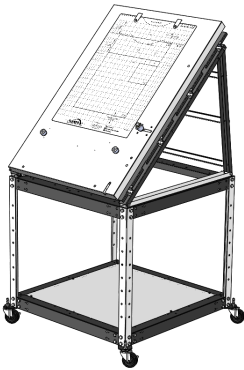

- 4) Optional **VRST** stand is used to support your pin board at an adjustable angle and height. The VRST stand is available with an OPTIONAL Drawer kit or screen rack. (POST-06/2018)

Assembly Doc: 01-13-005

5

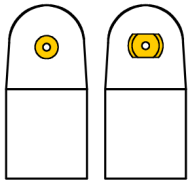

- 4) The **registration pins** are provided to fasten the clear carrier sheets to the pin board. The registration pins are anchor points for the setup sheets, allowing for precise placement of art work onto your screens.

6

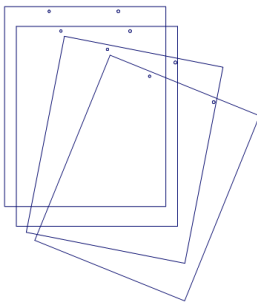

- 5) The **art carrier sheets**, individually, are a base for attaching each positive in precise position while using the printed grid on the pin board. Each pack of art carrier sheets will contain 12 clear sheets with punched holes on both sides.

7

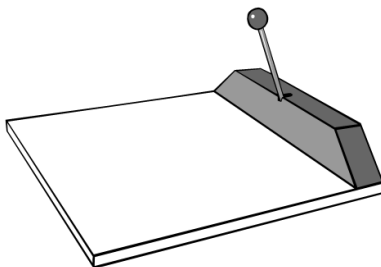

- 6) The (optional) **VRS carrier sheet hole punch** is a precision hole punching press that can punch multiple carrier sheets with the correct sized and positioned holes.

Pallet Jig Assembly—Rear Clamp

1) Install and tighten.

- (2) 3/4" Tall Jig Stops with 3/8-16 x 3/4" bolts, lock washers, and washers.

Tighten well using 9/16" wrench

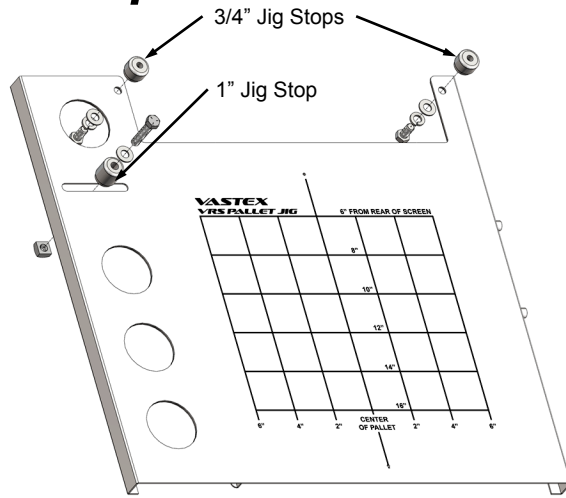

2) Install and leave loose.

- (1) 1" Tall Jig Stop with 3/8-16 x 1-3/4" bolt, washer, and square nut as shown.

This stop centers the screen on the Jig. Mark center on your screen, align it with the center mark on the Pallet Jig, and set the 1" Jig stop against the screen.

Then tighten with 9/16" wrench.

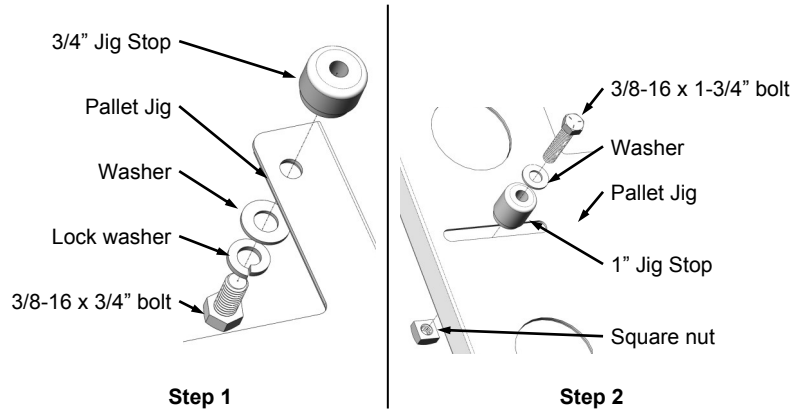

3) Install.

- (2) Clamps, springs, and thumb screws as shown. The clamps hook into the bottom of the Pallet Jig. See Illustrations 3a-3d below.

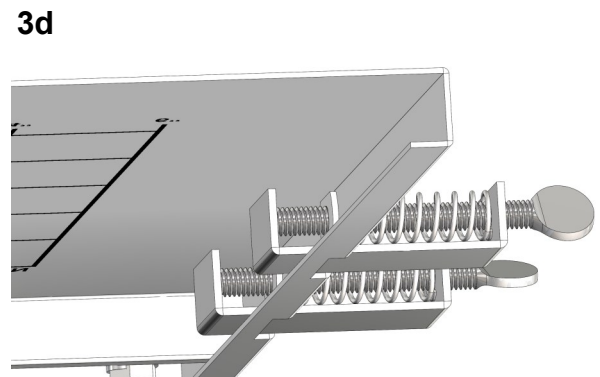
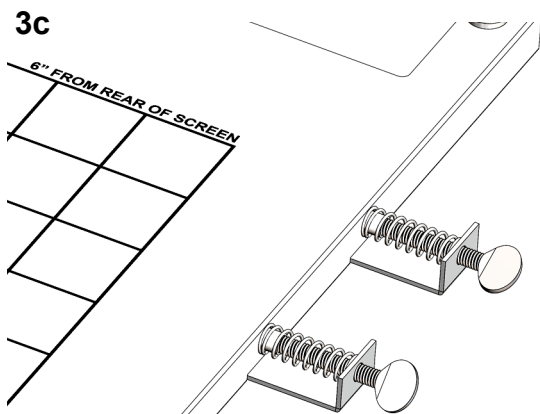
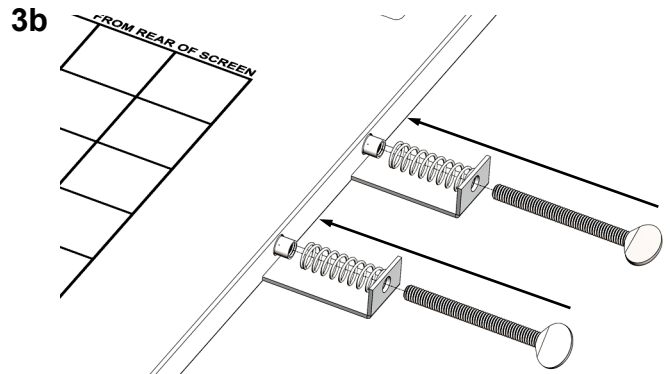
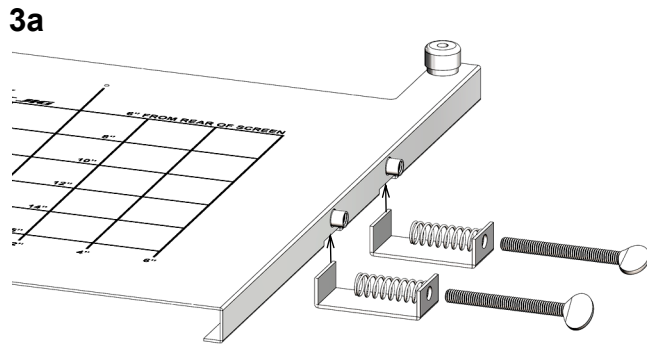

Pallet Jig Assembly—Side Clamp

1) Install and tighten.

- (2) 3/4" Tall Jig Stops with 3/8-16 x 3/4" bolts, lock washers, and washers.

Tighten well using 9/16" wrench

2) Install and leave loose.

- (1) 1" Tall Jig Stop with 3/8-16 x 1-3/4" bolt, washer, and square nut as shown.

This stop centers the screen on the Jig. Mark center on your screen, align it with the center mark on the Pallet Jig, and set the 1" Jig stop against the screen.

Then tighten with 9/16" wrench.

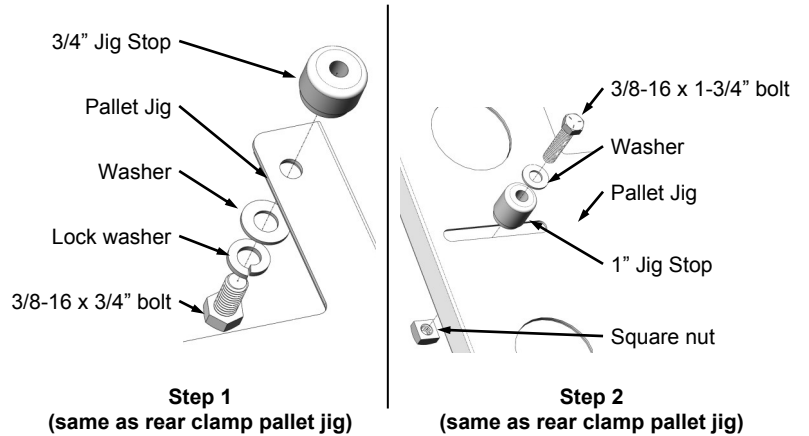
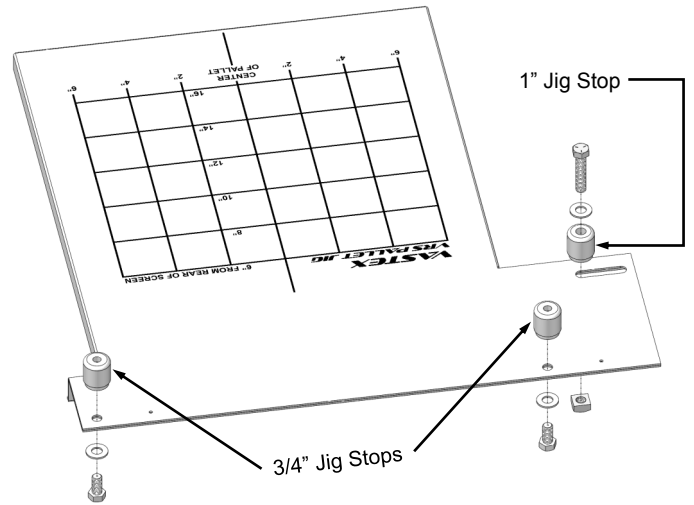

3) Install.

- (2) Clamps, springs, and knobs as shown. The clamps hook into the bottom of the Pallet Jig. See Illustrations 3a-3d below.

3a

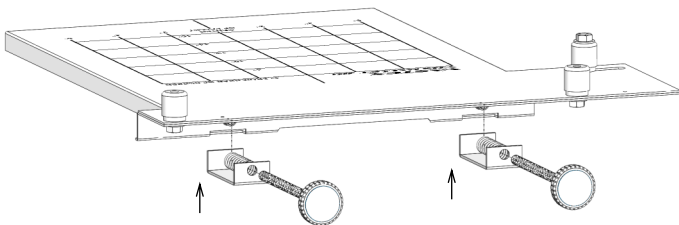

3b

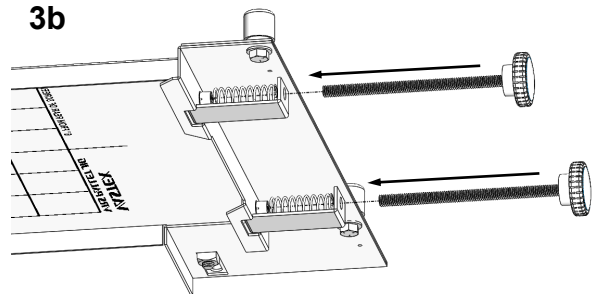

3c

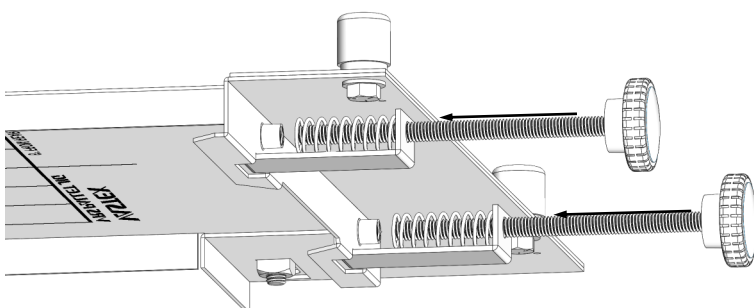

3d

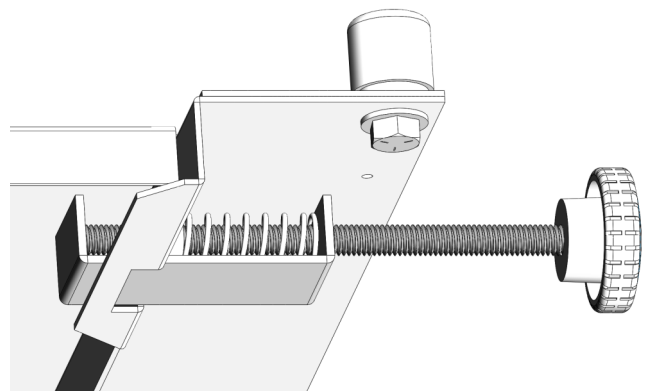

Pin Board Assembly

1) Install and tighten.

- (4) Rubber Feet, #10 washers, and 8-32 x 1/2" sheet metal screws

Tighten well using 1/4" wrench

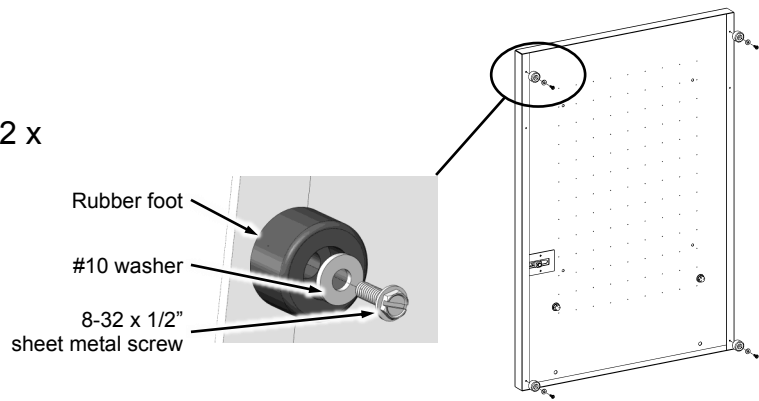

2) Install and tighten.

- (2) 3/4" Tall Jig Stops with 3/8-16 x 3/4" bolts, lock washers, and washers. There are 2 positions. Select appropriate holes for your screen size.

Then tighten with 9/16" wrench.

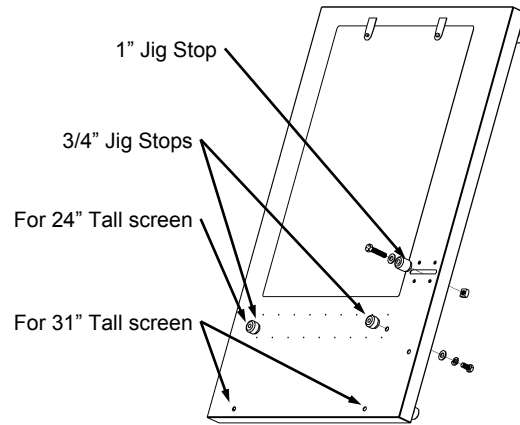

Pin Board Assembly

3) Install and leave loose

- (1) 1" Tall Jig Stop with 3/8-16 x 1-3/4" bolt, washer, and square nut as shown.

This stop centers the screen on the Jig. Mark center on your screen, align it with the center mark on the Pin Board, and set the 1" Jig stop against the screen.

Then tighten with 9/16" wrench

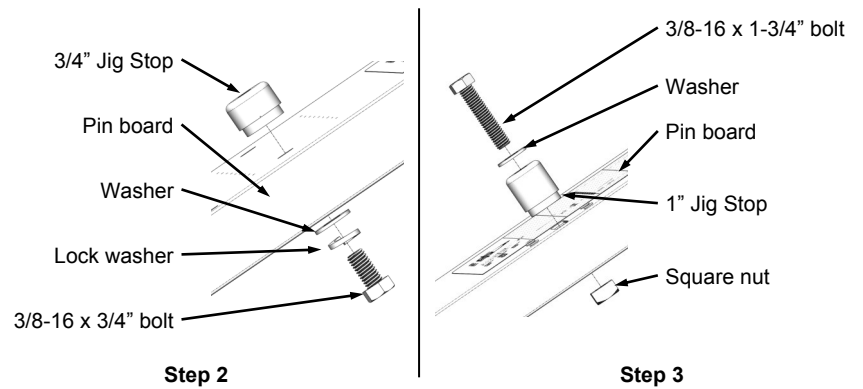

Step 2

Step 3

4) Install Pins and Tabs

(Normally installed at factory)

Locations shown on right. Side clamp and Rear Clamp Pin Boards use the same locations. Dimensions are to the center of the pins. Oblong pin on right.

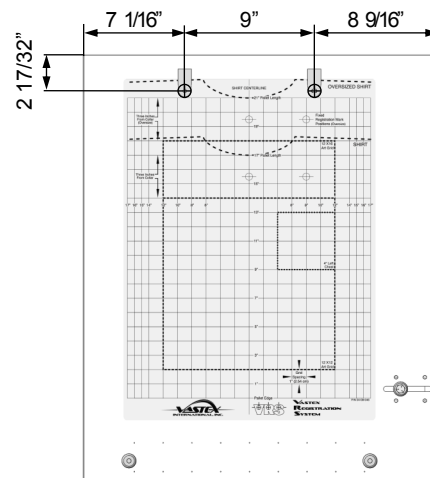

Pin and Tab Locations

Operation

This section outlines the operating methods for the Vastex VRS

Using the Pinboard (Method 1: For any exposing unit)

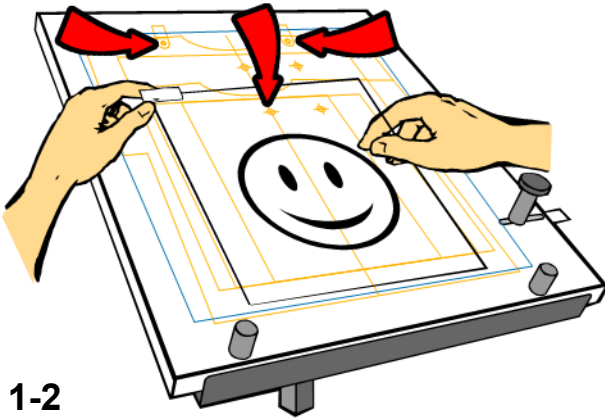

- 1) 1) Exposure systems without the VRS pin stops will use the art alignment grid and pins on the Pin Board. Place the carrier sheet onto the pins on the Pin Board. Align and tape your positive to the carrier sheet. Repeat this for all the positives for the job you are printing. When all the colors are on individual carrier sheets, choose the appropriate screens for your job.

- 2) The carrier sheets will be attached to the screens with double sided tape or tape facing sticky side up from the underside of the carrier sheets.

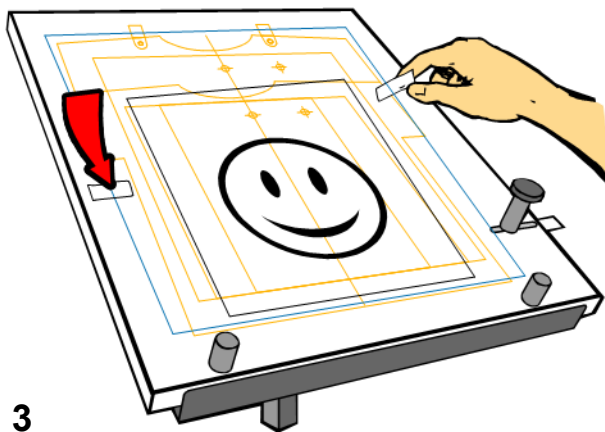

- 3) Carefully place the screen against the pin stops at the bottom and slide the screen over to the side stop (make sure not to move the carrier sheet and positive out of position). Press the screen to the carrier sheet to stick the tape to the screen. Remove the screen from the Pin Board and make sure the carrier sheet and positive is secure to the shirt side of the screen. Be careful not to tear the pin holes. Place the screen with the aligned positive onto your exposure system and expose.

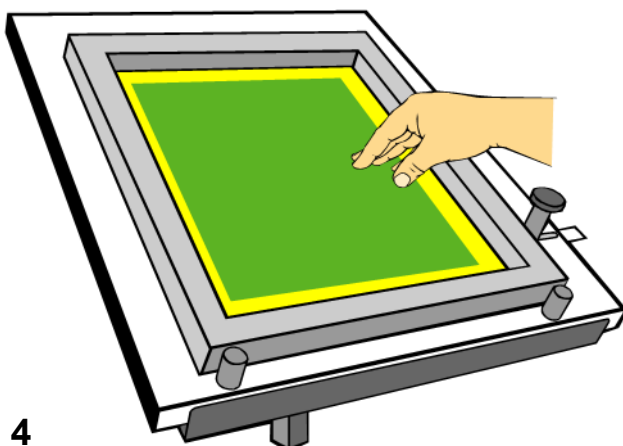

- 4) After exposure, remove the carrier sheet and positive from the screen. Wash and develop the emulsion as normal. When the screen is dry, prepare for installation into your press (tape and block out).

The following page shows how to use the VRS with a Vastex Expos-It equipped with pins/tabs and (optional) 3rd side stop.

Operation Cont'd

Using the Pinboard (Method 2: For manual presses using Vastex Expos-it)

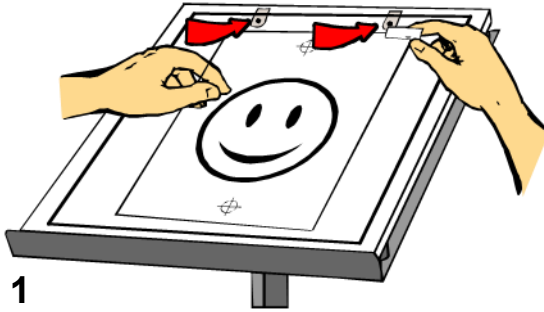

1

- 1) Place a single carrier sheet on the VRS pin board. Position the positive using the grid and pallet outline on the pin board as a reference. Tape the positive to the carrier sheet. The VRS works by holding the positive in the same position on the screens every time. It is essential that the user carefully aligns the positive on the carrier sheets to gain the most benefit from the VRS registration system. Artists can align additional colors by placing a second carrier sheet over the first sheet (with the aligned positive) and taping the second color positive to the second carrier sheet. Tip: With more than two colors make the first positive a "base" position. Stack the additional carrier sheets and positives only one at a time, as too thick of a stack of carrier sheets and positives will cause the colors not to align as well as possible (due to shadows and light refraction).

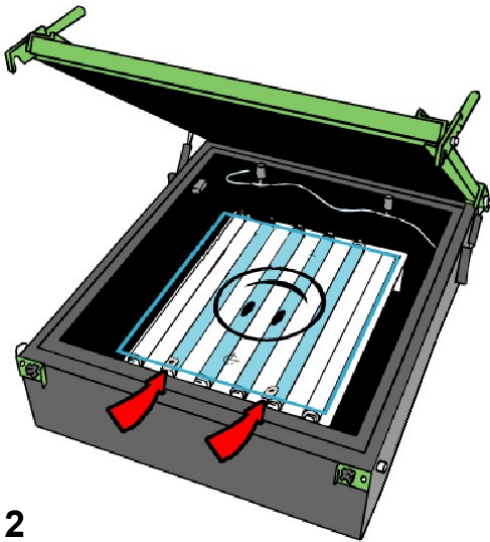

2

- 2) Place the positives onto the exposure glass using the registration pins, making sure that the carrier sheet and positive are flat to the glass and in correct position.

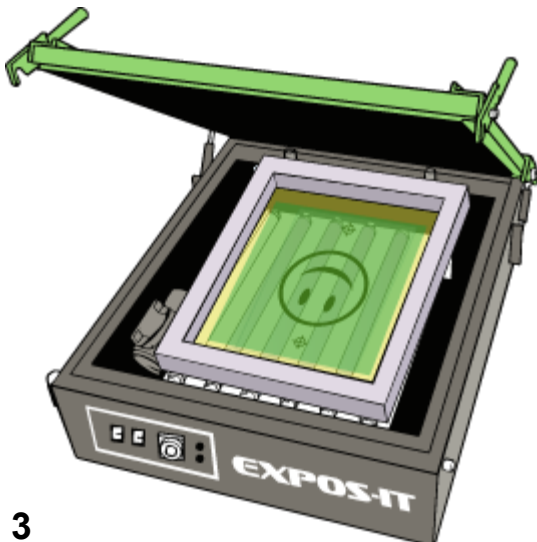

3

- 3) Gently push the screen against all three screen stops while lowering the exposit lid. Lock the lid closed, set the timer and expose your screen. Expose all remaining screens.

Operation Cont'd

Using the Pallet Jig (Manual press/jig shown)

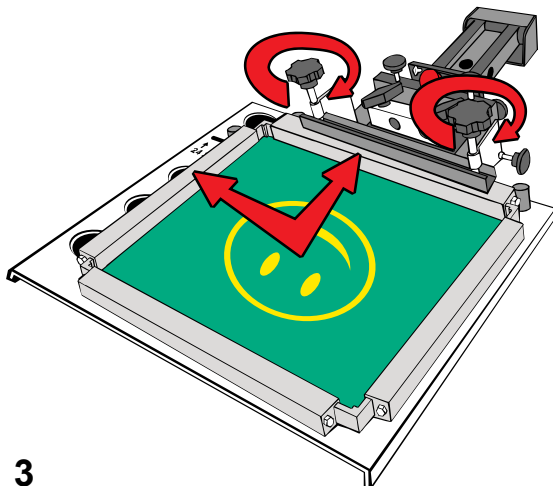
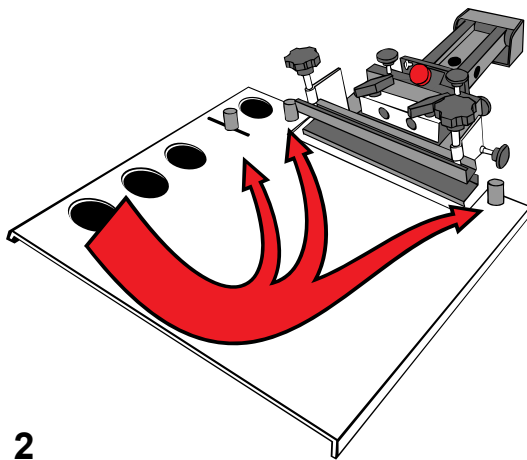
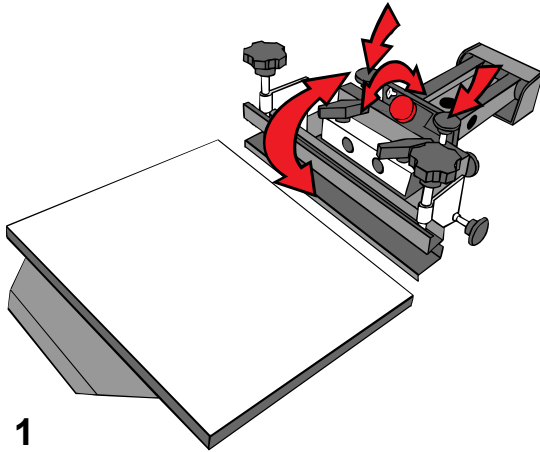

- 1) After exposure, remove the carrier sheet and positive from the screen and wash and develop the emulsion as normal. When the screen is dry, prepare for installation on your press (block out, tape). Center all the screen micro adjustments on the printer.
- 2) **Manual** users; Place the VRS Pallet Jig onto one pallet. The screen stops will be at the back and left side of pallet when facing center of the printer. Gently pull the pallet jig toward yourself until it stops against back edge of pallet. Lock in place using the two pallet clamps. Make sure to have centered or "zeroed" the micro registration adjustments on your printer before continuing.

Automatic users; Please refer to assembly drawing for your press for proper orientation of the pallet jig.

3) Manual Press

Slide the screen into position against the two back stops and slide the screen to the side stop. If the back edge of the screen is contacting the screen clamp it will be necessary to move the press pallet away from the clamp, allowing clearance between screen and clamp. When clearance has been obtained continue with screen installation. Hold the screen firmly against the pin stops while tightening the screen clamps. Repeat this procedure for any additional colors and use the micro registration adjustments for any final screen alignment. Platens can be moved once the screens are locked in position.

Automatic Press

Cycle pallet and screen to printing position. Slide screen into clamps. Gently push screen against all three stops, then activate clamps. Screen is now accurately located within the clamps and over the pallet. Rotate the pallet and pallet jig to the next station. Repeat this procedure for any additional colors and use the micro registration adjustments for any final screen alignment.

Operation Cont'd

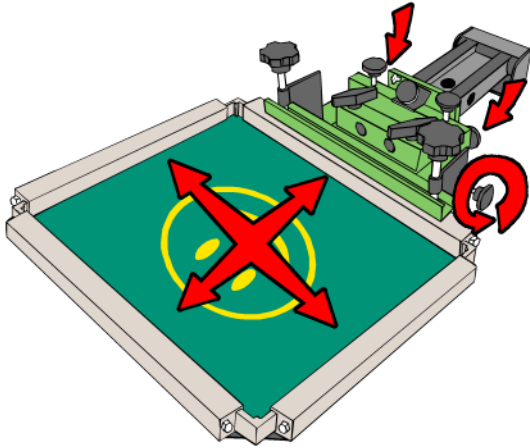

5

- 5) Use the micro registration adjustments for fine screen alignment.
- 6) Final screen alignment with the micros can be shortened by using the "tape trick". This trick is quick and allows for unlimited adjustments because the smooth tape surface can be wiped of ink with a shirt rag.

Using "The Tape Trick"

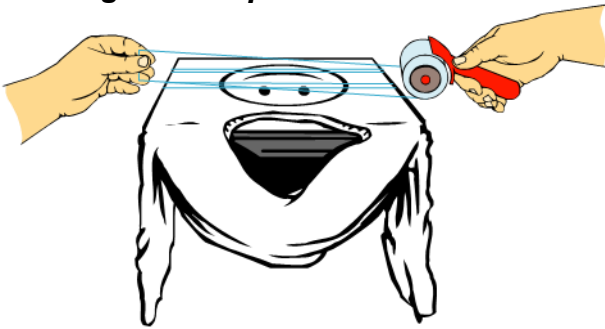

- 1) Apply a liberal amount of adhesive to the platen and place a print rag (large enough to cover the entire platen) on the platen.
- 2) Print the "alignment" color (this should be a color that contrasts with the rag color and touches or is part of all the other colors in the design) along with its registration marks. There is no need to flash (flashing may shrink the design).
- 3) Apply clear 2-3 inch packing tape over the entire design and registration marks (make sure to overlap the edges and smooth down the tape).
- 4) Move the next color into position and bring the print head down into the locks.
- 5) If critical registration is needed, print directly onto the tape and move the micro registration as needed.
- 6) If further alignment is needed, wipe the ink from the tape and proceed to make new micro adjustments as needed (print, adjust, wipe and repeat). When all the screens and the respective colors are in their final positions and locked remove the tape from the rag and discard it.

A complete video demonstration can be seen in the video section of our website. Just go to **WWW.VASTEX.COM** to see The Tape Trick, and a complete VRS demo.

