



# V-2000HD

Assembly, Operating, and Maintenance Instructions for all V-2000 rotary presses.



<b>Contents</b>	<b>Page#</b>
• Introduction– Please Read Thoroughly	2
• Safety Information	3
• Overall View	4
• Printer Assembly	5-7
• Printhead/Extension Arm Pics & PN	8
• Micro Registration Adjustment	9
• Level & Off Contact Adjustment	10
• Pallet Assembly	11
• Pallet Leveling	12
• Detent Wheel & Service Pan	13
• Lubrication / Maintenance	14-15
• 01-00-005B / 01-00-015 Warranty	16-17

**Vastex International, Inc.**  
 7 Emery St  
 Bethlehem, Pa. 18015 USA  
 Phone# 610 625-2702 Fax# 610 625-2775  
 Web Site [www.vastex.com](http://www.vastex.com)

Authorized Representative in Europe:  
 Certification Experts BV  
 Nieuwstad 100 1381 CE Weesp,  
 The Netherlands  
 Tel : + 31 (0) 294 – 48 33 55  
 Fax : + 31 (0) 294 – 41 46 87

**Vastex E-mail assistance**

Purchasing & Product Info:  
[sales@vastex.com](mailto:sales@vastex.com)

Electrical Support:  
[stech@vastex.com](mailto:stech@vastex.com)

Tech Support, Mechanical Setup, and Operation:  
[techsupport@vastex.com](mailto:techsupport@vastex.com)

Screen Printing Issues & Support:  
[printech@vastex.com](mailto:printech@vastex.com)

Serial Number: VTX\_\_\_\_\_ Date: \_\_\_/\_\_\_/\_\_\_

(Please log your machine's serial number and date of purchase for future reference.)

## **Introduction:**

**Thank you** for purchasing your printing equipment from Vastex International Inc.

Vastex has been designing and building printing equipment since 1960. We have knowledge and experience, and are proud to supply the printing industry with quality equipment at an affordable price. You can be confident your purchase will give you years of trouble free service.

## **Features:**

- Micro Registration
- Wrench-less Adjustments
- Steel pallets with rubber tops
- All heads down
- Upgradeable (Available up to 10x10)
- Tabletop units available

## **Options:**

- Additional color and station upgrade packages
- Unique, fast, numbering system attachment
- Super heavy duty print arms  
(hold up to 50lbs.[22.7kg] )
- Pallets– Request a Pallet Spec Book
- Side clamps, removable or fixed
- Stand (for tabletop version)
- Locking casters and levelers
- Service Pan (for extra storage) w/ locking casters

## **Safe handling, transport, and storage of the press:**

Your press is designed to be inherently safe under all normal conditions. When handling or transporting your press, be aware of the weight of your unit and have an appropriate number of people to lift the weight safely:

**V2HD-44: 400 lbs (182 kg)**      **V2HD-88: 750 lbs (340 kg)**      **V2HD-1010: 1075 lbs (488 kg)**  
**V2HD-46: 473 lbs (214.5 kg)**      **V2HD-66: 550 lbs (250 kg)**

If your press is to be moved or transported regularly, it is recommended that you purchase the optional casters.

## **Placing this equipment into service:**

To place your press into service —

- 1.) Review the photograph on page 4 to familiarize yourself with the parts of the press.
- 2.) Follow the instructions on pages 5 through 7.
- 3.) If necessary to make fine adjustments to your press, see pages 8 through 13.

## **Operating this equipment:**

To operate your press —

- 1.) Clamp your first screen into head #1.
- 2.) Repeat for additional screens, using additional heads.
- 3.) Place garment in pallet #1.
- 4.) Lower print head and squeegee ink through screen.
- 5.) Raise print head. For one-color printing, load new, blank garment and repeat steps above.
- 6.) For multi-color printing, rotate the pallet to print head #2 and repeat steps above until all colors are printed.
- 7.) If any adjustments to the print heads need to be made, refer to the instructions in this manual.

## **Safety during maintenance or while making adjustments:**

- When cleaning or lubricating your press, make sure that nobody in the work area is close enough to cause any part of the press to move unexpectedly.
- If gas springs are removed for inspection or replacement, be aware that they are under tension in the compressed position and take appropriate precautions to let them extend fully before removing.
- Do not remove springs unless under the specific direction of Vastex customer service.

## **In the event of an accident or breakdown:**

In the unlikely event that a part of your press breaks, or if your press does not seem to be operating normally and the instructions in this manual do not correct the issue, do not continue using your press. Contact Vastex for assistance in repairing your press.

## **Safety Information**

**Read this manual before assembling and operating your press.**

### **Intended Use:**

- **This equipment is intended for performing manual screen printing of fabric items, particularly garments. This equipment must not be used in a manner contrary to what is described in this manual.**

### **Safety:**

- **The operator should read and understand this manual before operating this equipment. Store manual and safety information near equipment for easy access to operators.**
- **Children and pets must be kept clear of the work area.**
- **Do not store any objects on top of any part of the press.**
- **Do not operate if any guard or cover has been removed.**
- **Noise and Vibration: This noise level produced by this equipment does not exceed 70 dB(A).**
- **Do not stand in locations other than the normal workstations (a workstation is the location directly in front of any pallet) when equipment is in use.**
- **This equipment has been designed with care to eliminate hazards as far as possible. However, by nature of its operation, there may be pinch points. Avoid placing hands or fingers in places where they could become pinched as print heads are lowered.**
- **In the unlikely event that a spring in the press breaks, the print head could fall rapidly. Keep hands and fingers away from the space between the print head and the pallet.**
- **As with any machinery having moving parts, it is suggested that the operator(s) wear safety glasses.**

Essential characteristics of tools which may be fitted to this machinery: this equipment is not designed to have tools or components added, except as specifically listed in this manual.

### **Stability during use, transportation, assembly, foreseeable breakdowns, etc.:**

This equipment is designed and expected to be stable during all normal conditions of use.

- **When assembling your press, do not stand tall parts upright until you are ready to install them; lay them flat instead.**
- **It is recommended that assembly should be done by two or more people, to facilitate the alignment of parts that must be bolted together.**
- **If one or more legs of the press will be removed, be certain to adequately support the rest of the press.**

# V-2000HD Overall View

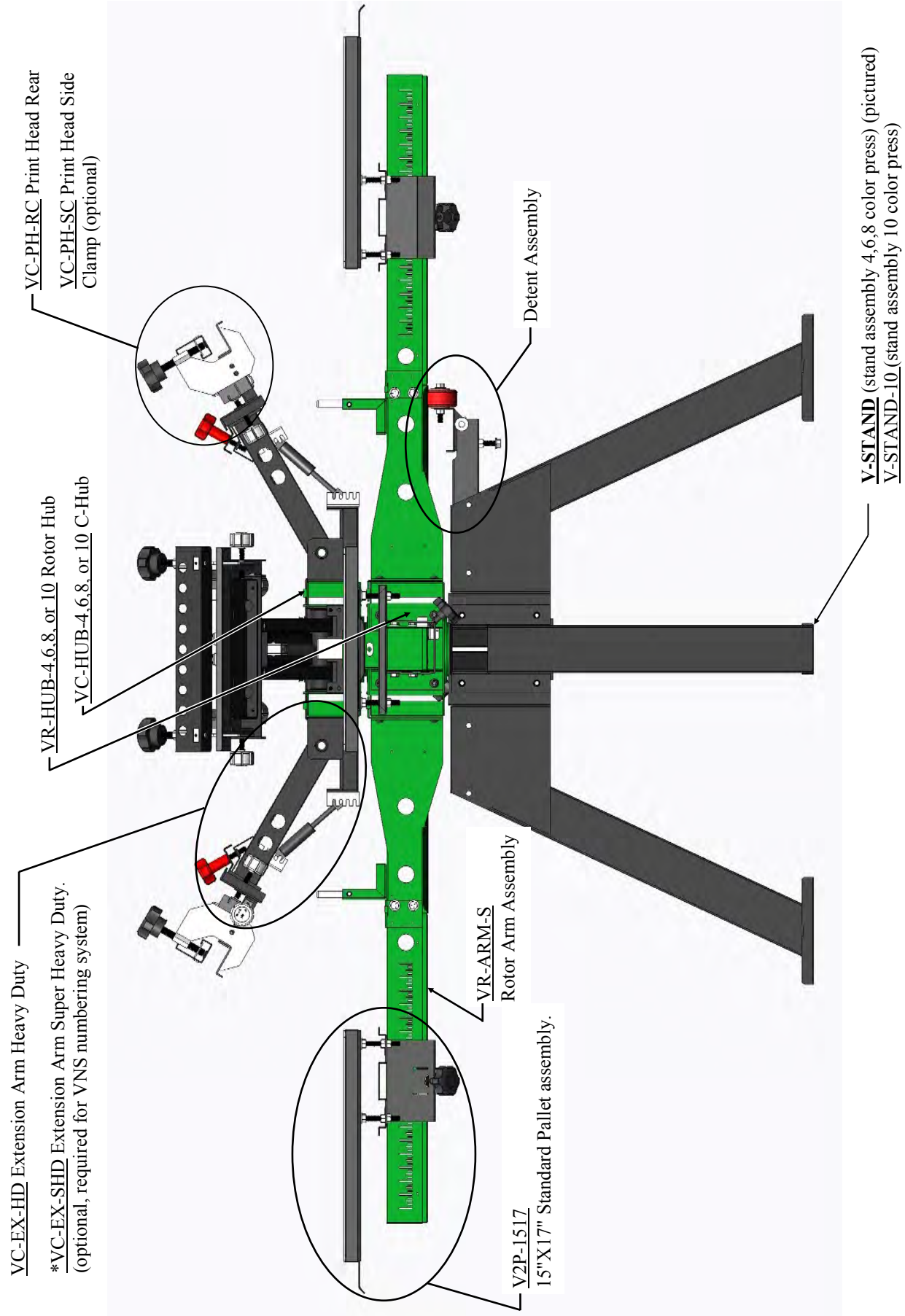

# Printer Assembly

- 1) **Remove straps, sides of crate, and shrink wrap** from around the press. Remove lag bolts holding the rotor arms to skid and unpack boxes under press.



Note: Report any box damage to the driver and note it on the ticket before signing. If hidden damage is found, report it to the **trucking company right away** and save the packaging.

- 2) **Take press off of skid**, by removing the lag bolts at the feet and carefully sliding the press off the skid and onto the shop floor.



Some accessories are packed with the press.

- 3) **Install your rotor arms. Be sure to put the arms into the correct numbered positions.** Each arm is packed with a pallet attached. Install the rotor arm as shown below. Two hooks hold the Rotor Arm in place before hardware is installed. Install (4) gold colored washers and (4) 3/8" bolts on each arm. Tighten these bolts Very Well.

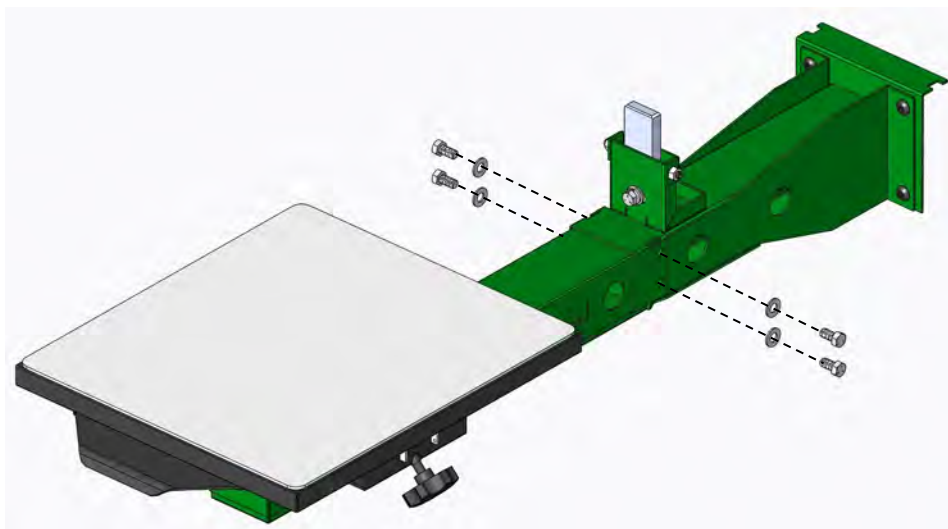
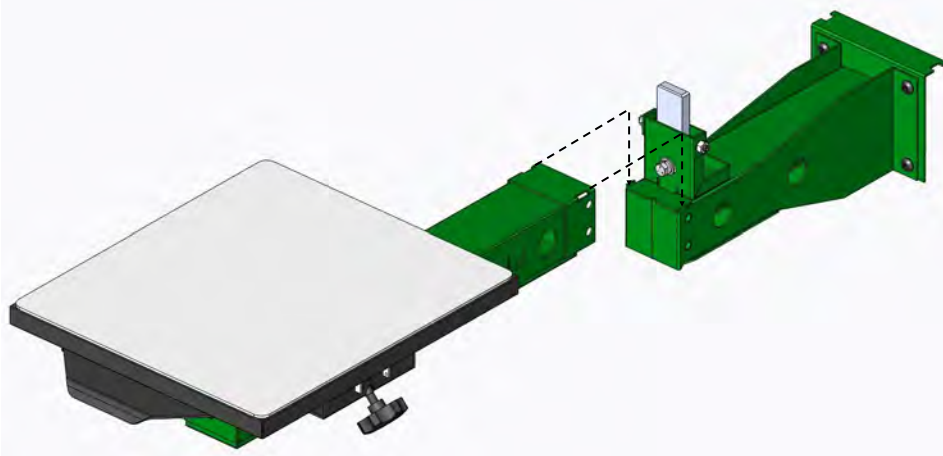

# Printer Assembly

4) **Install the gas springs, found in print head box,** with the number 1 head and the rotor arm bolts. There are 4 slots on each side to choose. Be sure the barrel is in the up position and for starters use the slots shown to the right.



*Note: The gas spring can be put into any slots to get the "feel" you like. Be sure to install with the barrel up as shown.*

5a) **Installing the Print Heads onto the Swivel Arms.** One print head has been leveled and #1 to match the swivel and extension arm #1. To install the Printheads, pull the mounting bolts forward.

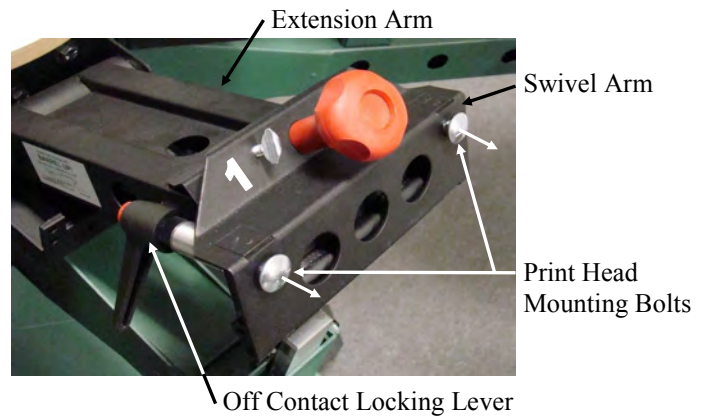

5b) Position the large holes in the print head back plate over the mounting bolts and slide down into the slots. **Be sure the head is slid all the way down in the slots.** Fully tighten only the Locking Levers of the #1 Print Head. The remaining Print Heads will be tightened after the Print Heads are leveled. The locking lever handle can be pulled out to allow rotation to another position, release to engage for locking.

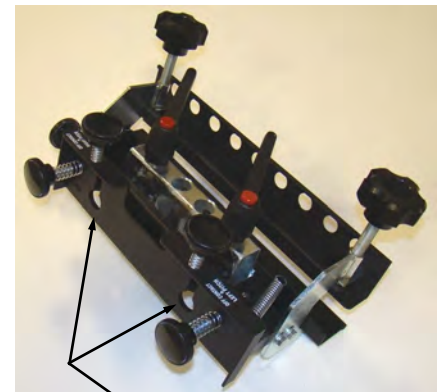

Print Head Back Plate Mounting Holes / Slots

Off Contact Locking Lever

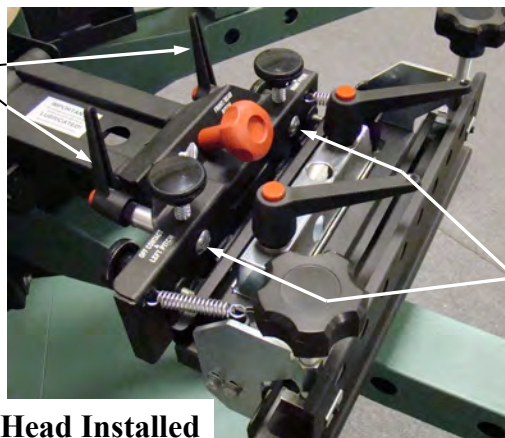

Print Head Mounting Bolts

Print Head Installed

# Printer Assembly

6) **Adjusting the remaining Print Heads.** Move the screen to remaining print head positions and set the 1/8" off contact to the now leveled pallets.

*Don't forget print head #1 was adjusted at the factory.*

But you may still have to make an adjustment due to variations in screens and possible movement in shipping. Please adjust the print head in this case not the pallet.

Clamp a flat screen into a print head. Using the "Front/Rear Pitch" knobs, the "Left/Right Pitch" knobs, and the Off Contact knobs, adjust the screen gap or "off contact" to 1/8". Please read the notes below before making adjustments.

- A. Tighten both Screen Clamp Knobs to secure the screen in the printhead.
- B. Loosen the Front Rear Lock Screw before adjusting the pitch. Retighten after adjusting.
- C. Loosen both Micro Clamp Levers before adjusting the left right pitch and "X" movement. Retighten after adjusting.
- D. Loosen both Off Contact Locking Levers. Set off contact. Retighten after adjusting.

## Printhead Component Identification

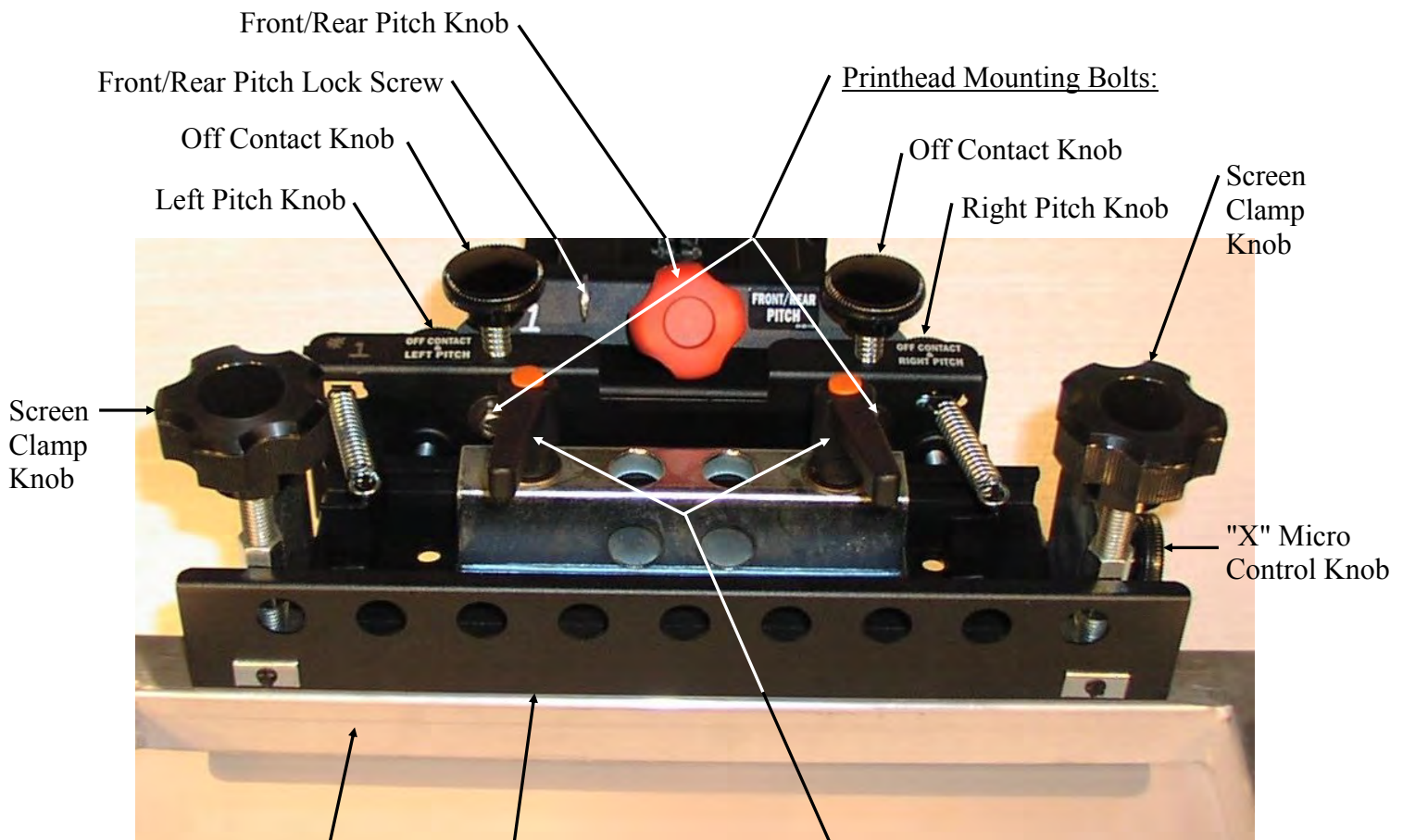

**Keep Inside of Screen and Clamp Bar flush!**

### MICRO CLAMP LEVERS:

Lift and rotate to a comfortable position. Only loosen and tighten levers while the head is in the down position.

# Vastex V-2000HD Print head/Extension Arm

## Vastex V-2000HD Print head/Extension Arm

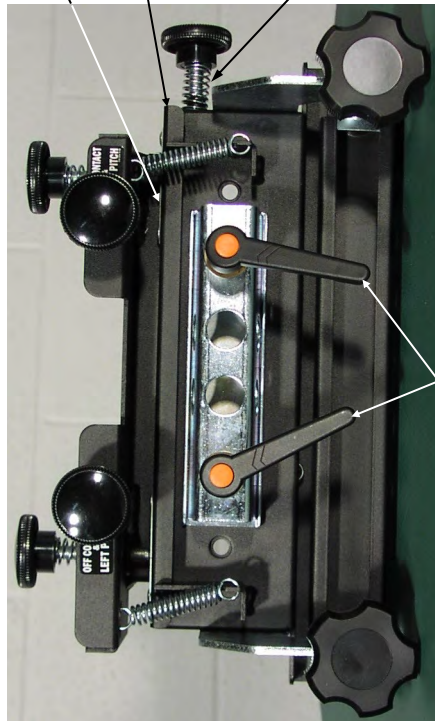

**VC-PH-RC**

- Micro Wear Strip (4) 05-05-017
- Screen Cab 05-05-011-1
- Spring, Micro Knob (3) 04-05-208

- Micro Lock Clamp Levers (2) 04-05-145

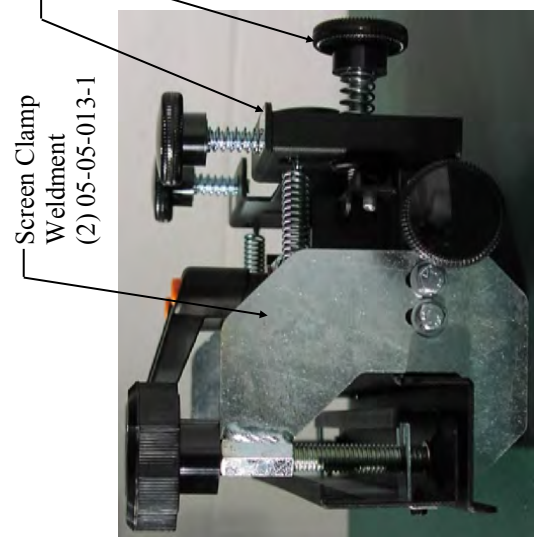

- Screen Clamp Weldment (2) 05-05-013-1
- Ground Plate 05-05-010-1
- (Micro Knob) Knob w/ Stud 3/8-16 x 2 1/4 (3) 04-05-150
- Clamp Bar 05-05-022-0
- Fork Retainer (2) 05-05-026-0

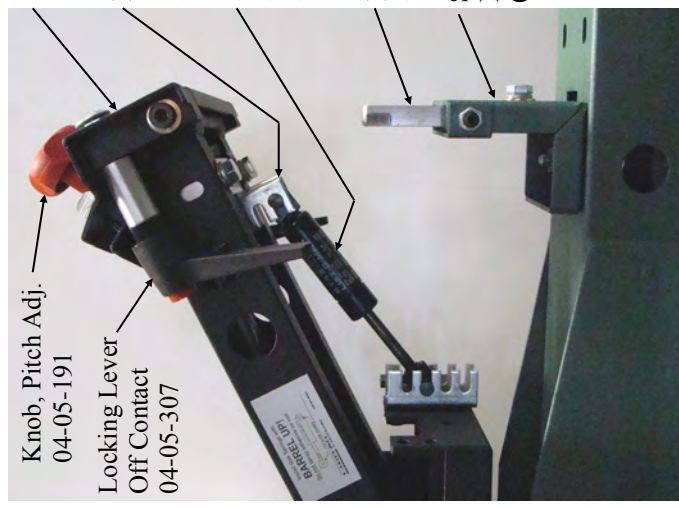

- Knob, Pitch Adj. 04-05-191
- Locking Lever Off Contact 04-05-307
- Swivel Arm 05-05-005-1
- Moving Point Spring Bracket 05-05-006
- Gas Spring 04-00-001
- Gas Spring Pin 05-05-018
- Registration Bar 05-04-005
- Support, Registration Bar Mount 05-04-021

**VC-EX-HD**

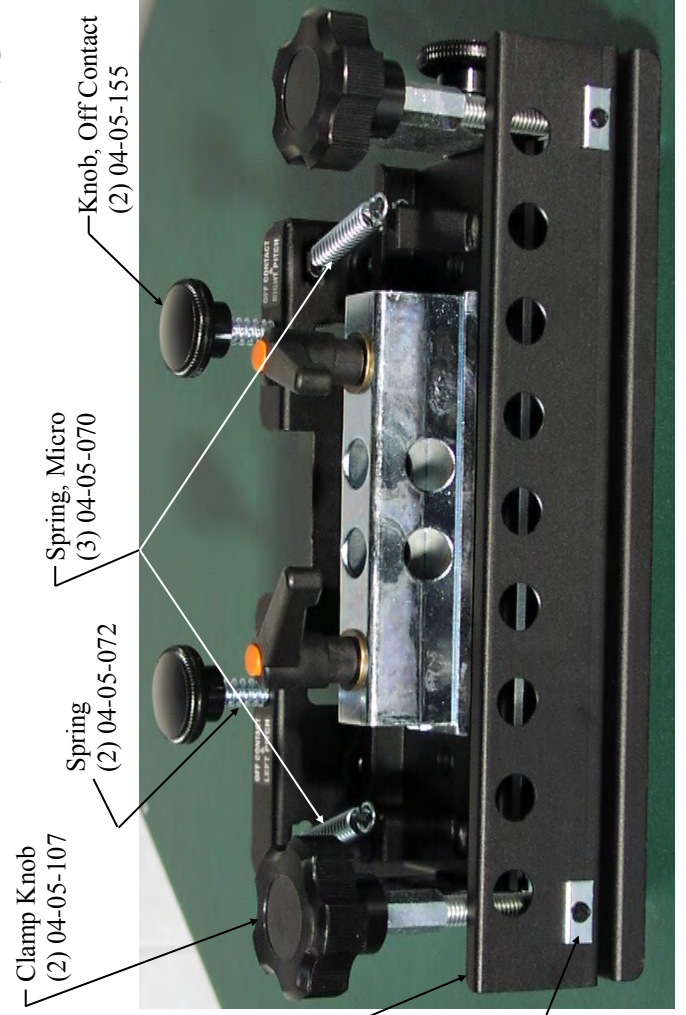

- Clamp Knob (2) 04-05-107
- Spring (2) 04-05-072
- Spring, Micro (3) 04-05-070
- Knob, Off Contact (2) 04-05-155



# Micro Registration Adjustment Instructions

Vastex micro-registration is standard with every V-2000 screen printer. It uses three control knobs, two micro clamp levers, and three return springs for movement control. A set of centering sites is used to start at a zero point. A total of 1/2" movement is available in the "X" direction and also in the "Y" direction

- Rotating the screen can be done by turning one of the "Y" micro control knobs. The pivot point for rotation is the tip of the other "Y" micro control knob.
  - The micro clamp levers must be loosened (1/4-1/2) turn only, before turning the control knobs.
- Start each job with the centering sites lined up. This ensures you will have all the available adjustment.

## To Move the Screen Left to Right

- 1) Loosen the two micro clamp levers (1/4-1/2) turn
- 2) Turn the "X" micro control knob clockwise (looking at the head) to move the screen to the right. Turn it counterclockwise to move the screen to the left.
- 3) Tighten the micro clamp levers and check the position. Repeat the above steps if necessary until the desired position is achieved.

*Note: The micro clamp levers may be lifted and rotated to any position desired. They must be down to be loosened or tightened.*

## To Move the Screen Front to Back or Rotate

- 1) Loosen the two micro clamp levers (1/4-1/2) turn.
- 2) Turn both "Y" micro control knobs clockwise (looking at the head) to move the screen toward you. Turn them counterclockwise to move the screen away from you. Turn one or the other to rotate the screen.
- 3) Tighten the micro clamp levers and check the position. Repeat the above steps, if necessary, until the desired position is achieved.

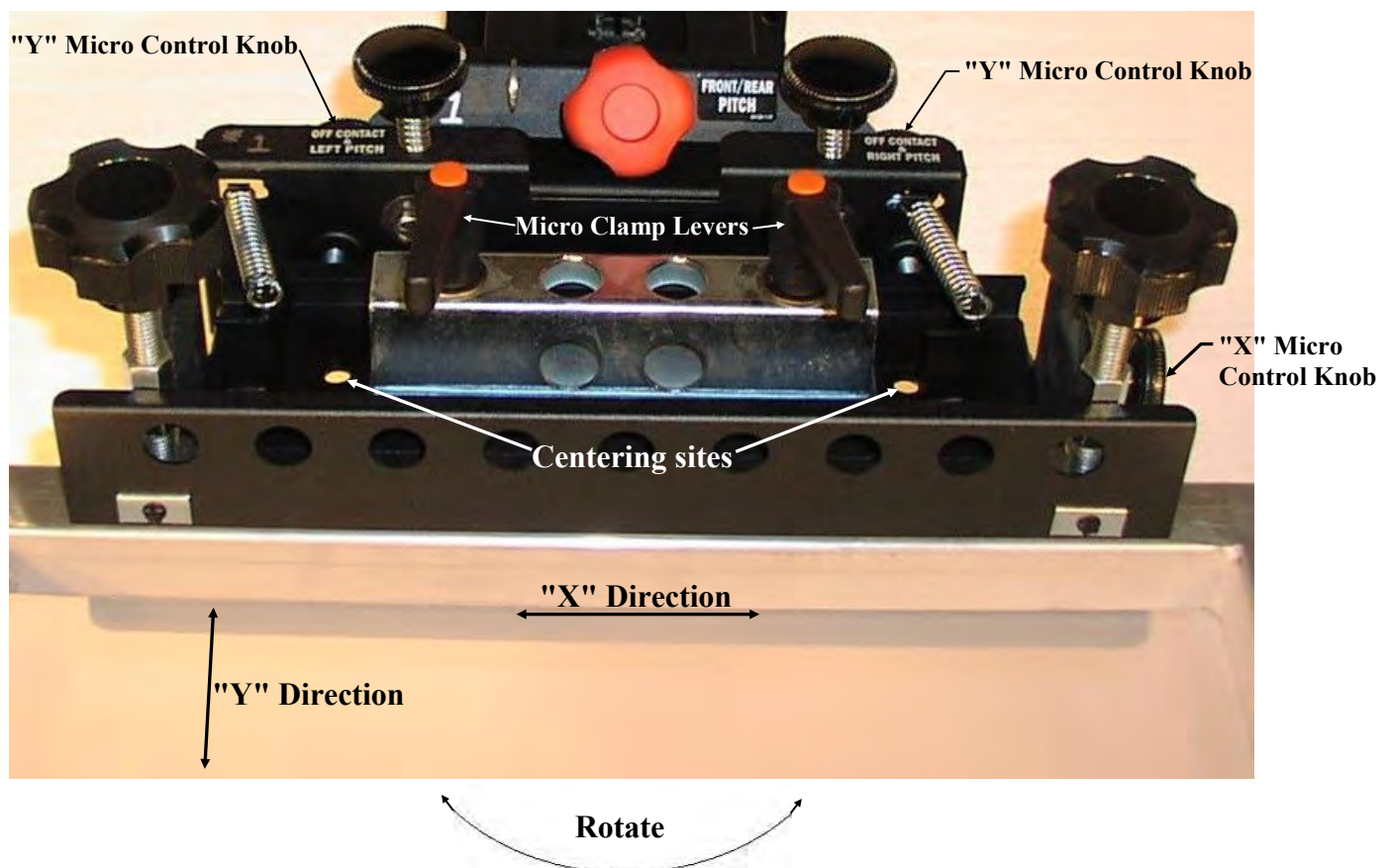

# Level & Off Contact Adjustments

The Vastex V-2000 comes standard with 6-way level adjustments.

- A. Tighten both Screen Clamp Knobs to secure the screen in the printhead.
- B. Loosen the Front Rear Lock Screw before adjusting the pitch. Retighten after adjusting.
- C. Loosen both Micro Clamp Levers before adjusting the left right pitch and “X” movement. Retighten after adjusting.
- D. Loosen both Off Contact Locking Levers. Set off contact. Retighten after adjusting.

Refer to **Printhead Component Identification** section for descriptions of knobs and levers.

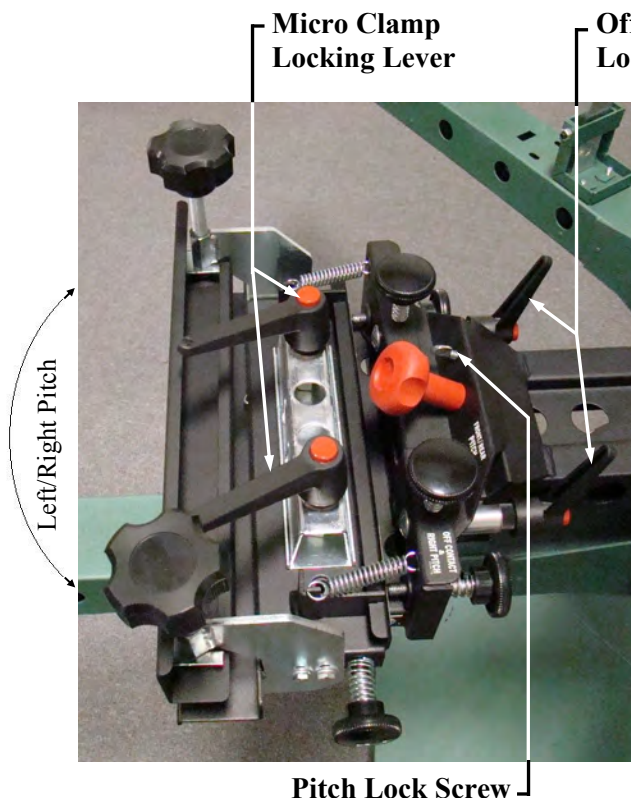

## Adjusting the Screen Off Contact:

- Be sure the screen is clamped tightly and both the Micro Clamp Levers and Off Contact Locking Levers are tight.
- There are two sets of adjustments that affect the off contact.
  - (1) The **Off Contact Knobs** control left to right level as well as screen off contact. Loosen slightly the Off Contact Locking Levers. Adjust the left / right pitch knob as needed. Do one side at a time while observing movement.
  - (2) The **Pitch Knob** controls the front to back level. The **Pitch Lock Screw** must be loosened to make this adjustment. Do not over tighten.

Follow these steps for each head. Head #1 is factory set.

- 1) Lower the print head to be leveled. Be sure all four locking levers and the pitch screw are tight.
- 2) If the screen is touching the pallet in one corner or more loosen one **Off Contact Locking Lever** and turn the **Off Contact Knobs** as needed. Adjust each side until the screen is level left to right and about 1/8” off the pallet. If the front of the screen is contacting the pallet it may be necessary to adjust pitch before off contact can be achieved.
- 3) Adjust the front to rear level by unlocking the **Pitch Locking Screw** and turning the **Pitch Knob**. Clockwise will lift the front of the screen and counter clockwise will lower. (It may be necessary to repeat step 2 after adjusting the front to rear pitch.)

Be sure to tighten all four levers and pitch lock screw before printing.

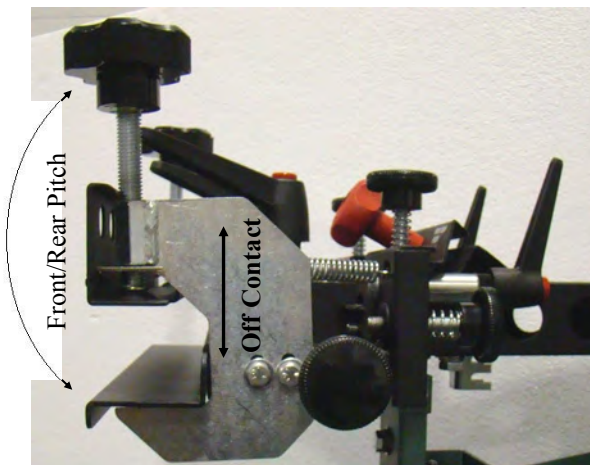

# Pallet Assembly

**Note:** All pallets have been preassembled and leveled at the factory since summer of 2010.

**The following procedure is for changing pallet tops, and/or pallet arms.**

- 1) Remove screws from neck guide  
-Using Flat Blade Screwdriver or 1/4" nut driver

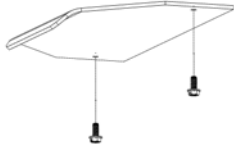

- 2) Install neck guide using screws from step 1  
-Tighten with Flat Blade Screw driver or 1/4" nut driver

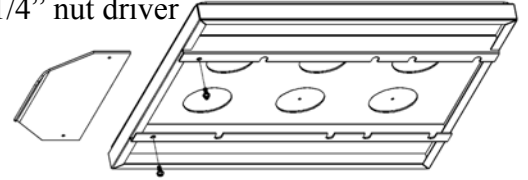

- 3) Install (4) 3/8-16 x 3" bolts, (8) 3/8" washers, and (8) 3/8-16 nuts as shown.  
-Tighten bottom nut with 9/16" wrench.  
-Set height as shown.

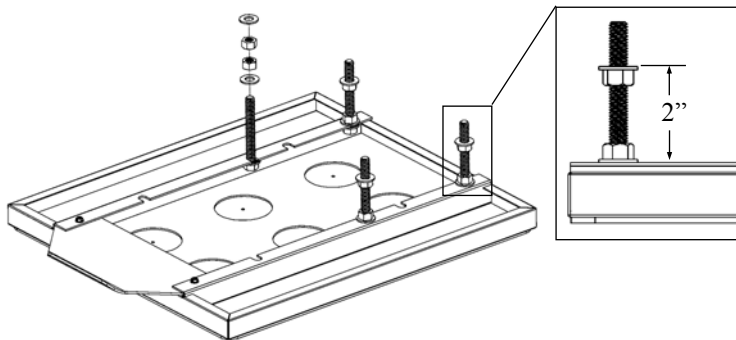

- 4) Install Pallet arm, (4) 3/8" washers, and (4) 3/8-16 nuts, as shown.  
-Tighten with (2) 9/16" wrenches

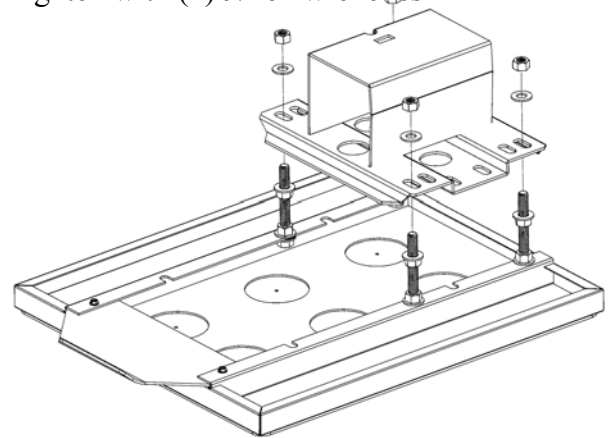

- 5) Install Corner Nut and knob as shown.  
Add grease (included) to thread of knob.

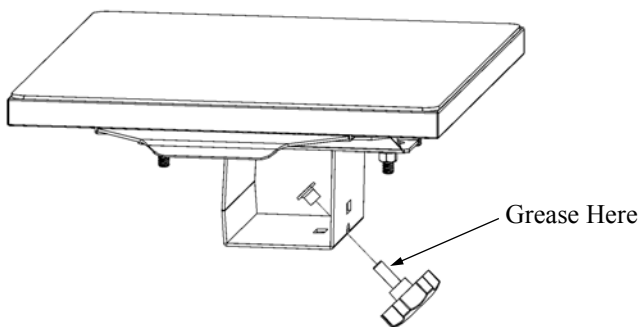

- 6) Install Corner Tab as shown

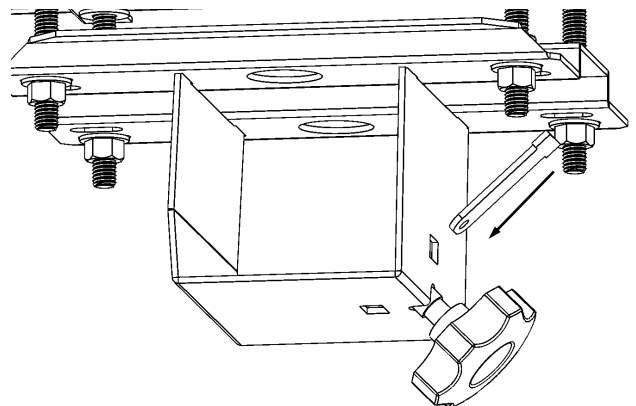

- 7) Install Clip as shown

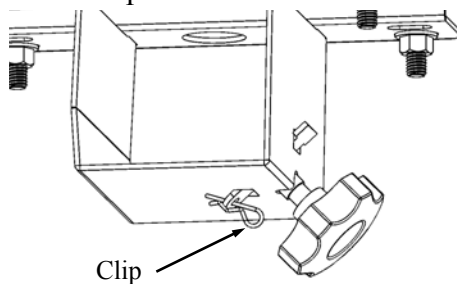

# Pallet Leveling

**Note:** All pallets have been preassembled and leveled at the factory since summer of 2010.

**If pallet leveling is required follow procedure below**

**The objective is:** To make the pallets and print heads **aligned and parallel** with approximately 1/8 off contact.

You do not need to use a bubble level on the pallets. You can level the machine to the floor if you like, but the important thing is the pallets need to be parallel to the screen mounted in the print head and centered over the rotor arms.

Remember print head #1 was adjusted at the factory. In the next few sections we will use print head #1 to adjust any pallets needing leveling then use the pallets to adjust the remaining print heads.

**IMPORTANT NOTE:** It is best to line up the inside of the screen with the front of the clamp bar any time you install screens in your V-2000 rear clamps.

1) **Place your best flat aluminum screen** into head #1 and lower it over pallet #1. Align side of screen with side of pallet as shown. **Do not remove this screen until all pallets have been set.**

*Be sure the gas spring is in a position that allows the screen to stay down by itself.*

Observe the “off contact” in all four corners of the pallet. It should be approximately 1/8”.

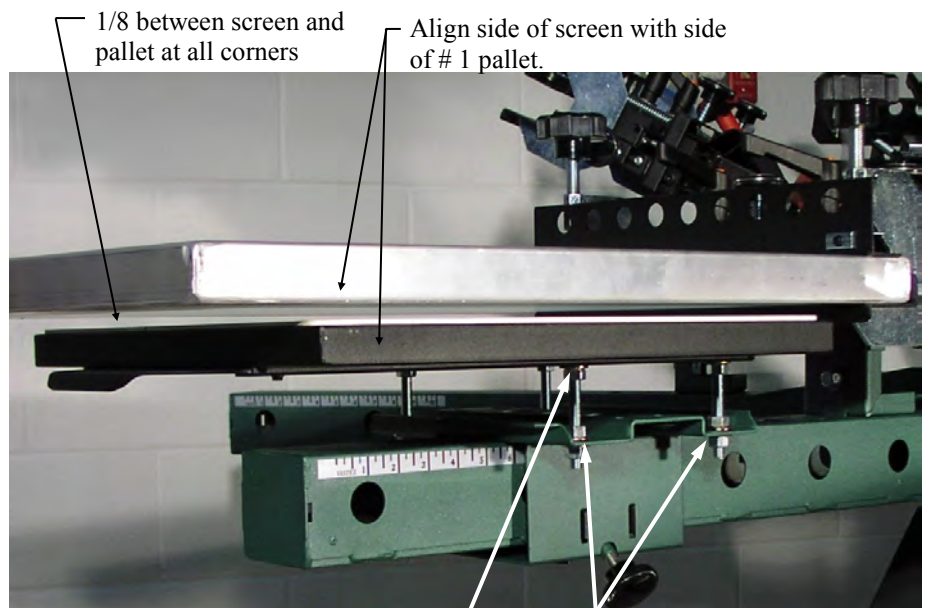

These nuts should have been tightened at pallet assembly.

Pallet leveling bolts & nuts

**#1 Rotor Arm, Pallet, & Print Head Shown Above**

2) **Lower the # 1 print head with the already installed screen over another pallet.** The pallet leveling nuts should be finger tight while setting side alignment and off contact. Align the side of the pallet to the side of screen. **Do not** move the screen to the pallet, move the pallet to the screen. Adjust the nuts at the bottom of the pallet leveling bolts to set the off contact to approximately 1/8”. When 1/8” off contact has been achieved at all corners and the pallet and screen sides are flush proceed to tighten all pallet nuts. **It is important that a good quality flat screen is used while making these adjustments.** Repeat for all remaining pallets.

# Detent Wheel Adjustment

Doc # 01-08-034A

## Detent Rocker Assembly

The Detent Rocker is used to achieve a repeatable position for the pallet under your flash. It can be set to lock the arm very firmly, loosely, or can be disabled altogether to remove the indexing feature.

The Detent Wheel is adjustable. To adjust; Loosen the nut, with (2) 9/16 wrenches. Move the wheel up, to increase, or down, to decrease, the Rotor Arm holding pressure.

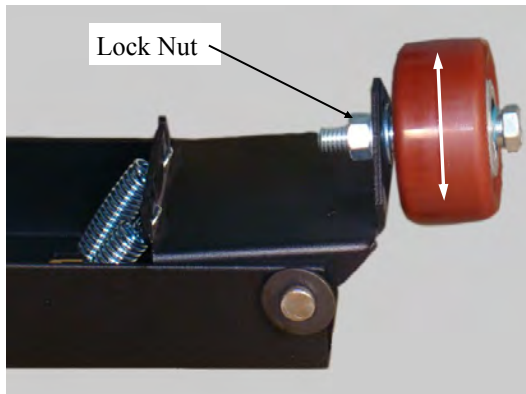

V2HD Printers built before Jan. 1, 2012

The Detent Wheel is adjustable. To adjust; Loosen the lock nut with a 9/16" wrench. Turn the screw out to increase or in to decrease holding pressure. Retighten locking nut after adjusting.

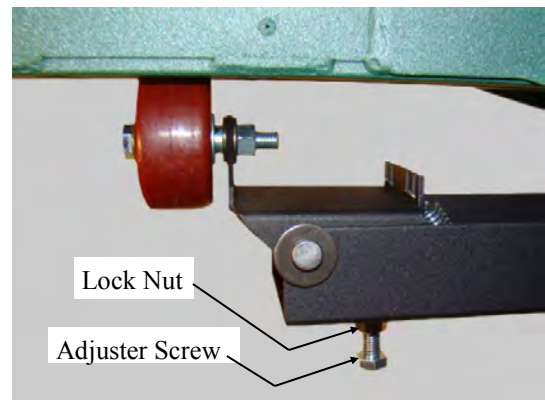

V2HD Printers built after Jan. 1, 2012

## Service Pan and Wheels (optional)

Wheels are installed with 1/2" hardware and foot brace. The brace goes under the foot and the wheel goes through both the foot and brace (shown below). Use the serrated 1/2" locknuts to attach the wheels to the feet.



Service Pan is installed by laying the Pan on the floor and rolling the machine over the Service Pan. The Service Pan can also be installed by removing one wheel (must have two people for this). Line it up with the holes on the inside of the press' feet. Lift the pan and install 1/2" hardware, using the flat washer on the bottom of the Service Pan

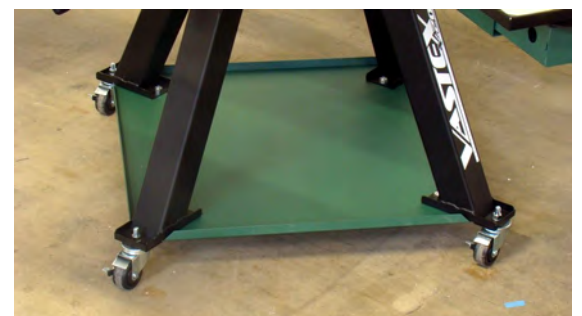
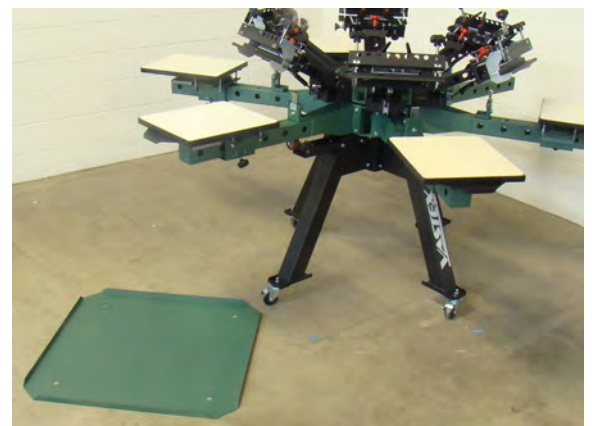

# V-2000 Lubrication and Maintenance

Doc # 01-08-045

**\*\* Please follow all Lubrication instructions to prevent premature wear \*\***  
**Lubricate monthly**

Supplied Lubricants:

- 1) Light Machine Oil (SAE 20 or equal)
  - 2) Thread Lubricant (White Lithium Grease) or Anti Seize
- Brush a small dab of lubricant to threads and a thin layer on three wear plates. Remove knobs and levers as needed to allow for proper application. See next page for tips.

Replacement Lubricants can be ordered at  
Vastex International Inc.  
P/N 04-05-300 Oil 4 oz.  
04-05-301 Grease 1.5 oz.

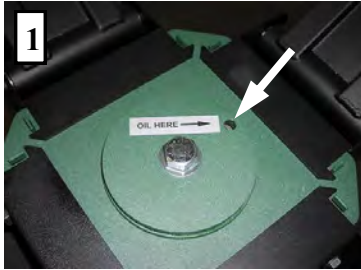

**Center Hub Bearings**  
Light Machine Oil (1/2 Oz.)

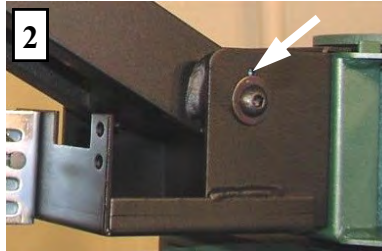

**Extension Arm Hinge**  
Light Machine Oil  
Several drops monthly  
(both sides)

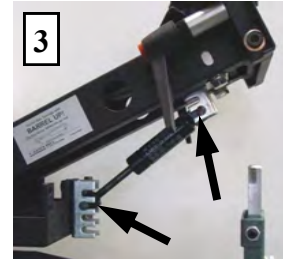

**Gas Spring Pins**  
Thread Lubricant

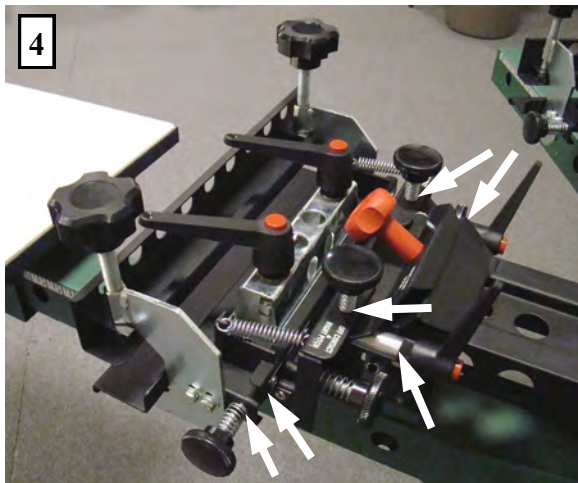

**Off Contact Locking Levers**  
Thread Lubricant  
**Off Contact Right/Left Knob**  
**“X” Axis Knob & Wear Plate**  
Thread Lubricant

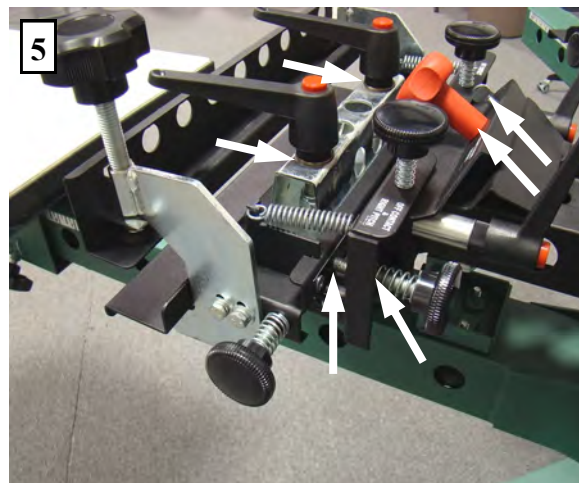

**Micro Adj. Locking Levers**  
**Micro Adj. Knobs & Wear Plates** (both sides)  
**Front / rear Pitch Knob, Locking Screw**  
Thread Lubricants

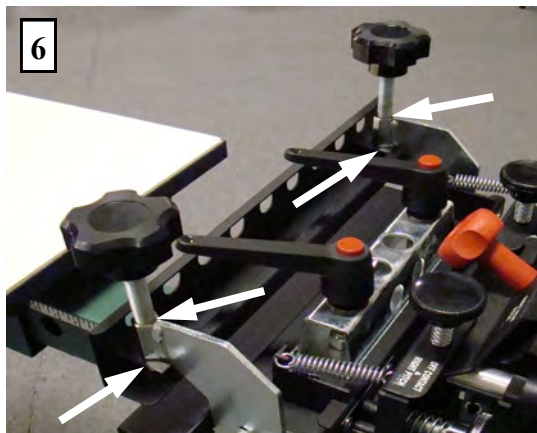

**Screen Clamping Knobs**  
Thread Lubricants



**Pallet Corner Clamping Knob**  
Thread Lubricant  
(lubricate threads and contact point stud to Corner Washer)

# V-2000 Lubrication and Maintenance

## **Cleaning**

- Clean your machine on a daily basis or between each job. Particularly removing lint around moving points and adjustment areas. A clean machine is more likely to be maintained properly than a messy one. Any solvents can be used on the pallet tops for cleaning. The painted surfaces should be cleaned with detergent, like a glass or multi-surface cleaner, to remove lint and dust. Mineral spirits can be used to remove spilled inks. Avoid spraying pallet adhesive on the gas springs to ensure their longevity.

## **Inspection**

- Inspect your machine on a monthly basis for untimely wear or any other signs of problems. This can be done while lubricating and should take no more than a few minutes. Finding a problem early can reduce the cost of downtime and repair.

## **Notes:**

# Vastex Warranty

Doc#01-00-005D Revised 2/20/2018

(1.) Vastex, hereinafter referred to as "seller" warrants only to its original "purchaser", who holds a copy of the original invoice and is the original end user of the equipment in question, its new equipment against manufacturer defects in materials or workmanship on a pro-rated basis. Warranty period begins from date of shipment to the buyer and will only apply to customers paid in full. Warranty periods are as follows: one (1) year for E-1000, three (3) years for all other complete machines (including F-Flash), fifteen (15) years for infrared heaters (excluding F-Flash) installed by Vastex in a new dryer, three (3) years for replacement infrared heaters, and one (1) year for replacement parts. Rubber blankets, light bulbs and glass on exposure units are particularly subject to wear while in use. Wear is not covered by this warranty but as stated above only manufacturers defects are covered. All sales made through Vastex dealers must be certified by that dealer before a warranty replacement is issued. All equipment is thoroughly tested and inspected before packaging. This warranty does not cover minor cosmetic damages that occur during shipment that do not affect the functionality of the equipment.

(2.) This warranty is expressly contingent upon the buyer delivering to seller, at the address below, with all transportation charges prepaid, the part or parts claimed to be defective within the above mentioned warranty periods stated in paragraph one. The defective part or parts will be repaired or replaced at the discretion of Vastex International, Inc. If the equipment in question is less than one (1) year old, it will be shipped to the customer at no charge, with an RGA issued by Vastex for the defective part. The defective part must be shipped back to Vastex freight prepaid within 30 days or the account will be billed. If the equipment is more than a year old, the part will be shipped after we receive the defective part. If it's necessary to expedite the movement of parts and to minimize down time to the buyer, the replacement part shall be supplied on a C.O.D. basis. If testing and analysis of said part by the seller or its supplier discloses that said part is defective, the cost of said part will be refunded to the buyer on a prorated basis.

(3.) Except as otherwise provided herein, the equipment is being sold "as-is". Final determination of the suitability of the equipment for the use contemplated by the buyer, is the sole responsibility of buyer, and seller shall have no responsibility in connection with the suitability.

(4.) All warranties implied by law, including the implied warranties of merchantability and fitness are hereby limited to manufacturer defects in materials or workmanship during the warranty period stated in paragraph one. The express warranty and remedies contained herein and such implied limited warranties are made solely to the sole warranties and remedies and are in lieu of all other warranties, guarantees, agreements, and other liabilities, whether express or implied, and all other remedies for breach of warranty or any other liability of seller, in no event shall seller be liable for consequential damages.

No person, agent, distributor, or service representative is authorized to change, modify or extend the terms hereof in any manner whatsoever.

These terms and conditions are an essential part of the transaction between the parties and constitute the entire agreement between them with respect to the same.

Some states do not allow limitation on how long an implied warranty lasts of the exclusion or limitation of incidental, or consequential damages, so the above limitation may not apply to you.

This warranty gives you specific legal rights, and you may also have other rights which vary from state to state.

Infrared heaters are the only replacement parts covered for a period of (3) years from date of shipment and contingent to receipt of payment in full.

Electrical components cannot be returned once installed unless proven defective.

Please refer to doc. 01-00-015 for specific terms and conditions of sale and the limited warranty.

Please refer to doc. 01-00-017 for V-2000HD printer warranty.

Updates: V1000 to 3 year warranty 01/09/12, Heater warranty to 15 years 01/02/2012.

## TERMS AND CONDITIONS OF SALE AND LIMITED WARRANTY Doc.#01-00-015

- Buyer's order will constitute an offer in accordance with the terms hereof and such offer, upon acknowledgment of Seller, will constitute the agreement between Buyer and Seller. Buyer's order after such acknowledgment by Seller will not be subject to cancellation, change or reduction in amount, or suspension by Buyer of deliveries, unless prior to such action Buyer has obtained Seller's written consent. Notwithstanding anything to the contrary in Buyer's Purchase Order or other communications, the parties agree to be bound by these Terms and Conditions. Acceptance of the product by the Buyer shall be deemed to constitute unconditional acceptance of these Terms and Conditions.
- Any of these terms, conditions and provisions of Buyer's order which are inconsistent with Seller's acknowledgment and these Terms and Conditions of Sale shall not be binding on the Seller and shall be considered not applicable to any sale so made. No waiver, alteration or modification of any of the provisions on either side of the document shall be binding upon Seller unless agreed to in writing by Seller.
- (a) All prices are F.O.B. Seller's Plant and method of delivery and routing shall be at Seller's discretion, unless specifically otherwise stated herein. Notwithstanding any agreement to pay freight, delivery of products purchased hereunder to a common carrier or licensed trucker shall constitute delivery to Buyer and be determinative of the date and time of shipment and all risk of loss or damage in transit shall be borne by Buyer. If the Buyer fails to accept the goods from the common carrier or licensed trucker, the Seller shall be entitled to claim payment from the Buyer. Seller shall arrange for storage, the risk and the cost, including insurance costs, to be borne by the Buyer (and Buyer agrees to pay such amounts upon demand) except if the failure to accept delivery is due to any of the exceptions noted in Paragraph 4.  
(b) Terms of payment shall be as stated on invoice.
- It is understood that deliveries will be made in accordance with Seller's regular production schedule. Every reasonable effort will be made to meet the Buyer's required delivery dates but Seller will not be liable for damages or be deemed to be in default by reason of any failure to deliver or delay in delivery due to any preference, priority, allocation or allotment order issued by the Government, whether Federal, State or local, or causes beyond its control including but not limited to, Acts of God or a public enemy, acts of Government, fires, floods, epidemics, quarantine restrictions, strikes, lockouts, freight embargoes, severe weather, unavailability of materials or shipping space, delays of carriers or suppliers or delays of any subcontractors. Should delay in delivery be caused by any of the circumstances mentioned in this paragraph, such extension of the delivery period shall be granted as is reasonable under the circumstances of the case. Should delay be caused by an event not specifically mentioned in this paragraph, damages will be limited to cancellation of the purchase order without penalty, and refund of any monies deposited or prepaid on the purchase order with no liability for any consequential or incidental damages.
- Seller reserves the right to increase the prices prior to Seller's acceptance of order and/or after expiration of any price quoted by Seller.
- Unless otherwise stated in writing, Seller's prices do not include sales, excise, value-added or other taxes. Consequently, in addition to the price specified herein, the amount of any present or future sales, use, excise, value-added or other tax applicable to the manufacture, sale, purchase or use of the products hereunder shall be paid by Buyer, or in lieu thereof, Buyer shall provide Seller with a valid tax exemption certificate acceptable to the taxing authorities.
- Seller reserves the right, at any time, to revoke any credit extended to Buyer because of Buyer's failure to pay for any products when due or for any other reason deemed good and sufficient by Seller and in such event, all subsequent shipments shall be paid for prior to at delivery at Seller's option.
- (a) SELLER'S LIABILITY SHALL BE LIMITED TO SELLER'S STATED SELLING PRICE PER UNIT OF ANY DEFECTIVE GOODS AND SHALL IN NO EVENT INCLUDE BUYER'S MANUFACTURING COSTS, LOST PROFITS, GOODWILL, OR ANY OTHER SPECIAL, INDIRECT, INCIDENTAL OR CONSEQUENTIAL DAMAGES, ARISING OUT OF THE AGREEMENT, THIS CONTRACT, THE SALE OF THE PRODUCTS TO THE BUYER OR THE USE OR THE PERFORMANCE OF THE PRODUCTS. Seller may at its discretion repair, replace or give the Buyer credit (pro-rated) for such defective products.  
(b) Notwithstanding anything herein to the contrary, Seller shall have no liability for alleged defects with the products which are not specified in written notice from the Buyer to the Seller within thirty-six (36) months from the date of shipment of machines. Seller shall pass to Buyer any warranty received by Seller from the manufacturer of Limited Life Components, which in most cases is 12 to 18 months.  
(c) Seller shall have no liability under this Limited Warranty unless Buyer has paid in full for the products. Further, this Limited Warranty is expressly contingent on Buyer's delivery to Seller, all costs prepaid, the defective part(s) within thirty-six (36) months of shipment to Buyer, together with a written statement specifying the alleged defect(s). Any replacement part(s) shall be shipped to Buyer on a C.O.D. basis.  
(d) SELLER SPECIFICALLY EXCLUDES ALL WARRANTIES, EXPRESSED, IMPLIED OR OTHERWISE, EXCEPT AS STATED EXPLICITLY IN THESE TERMS AND CONDITIONS OF SALE. SELLER DISCLAIMS THE WARRANTY OF MERCHANTABILITY AND FITNESS FOR A PARTICULAR PURPOSE.
- The remedies herein reserved by Seller shall be cumulative and in addition to any other legal remedies. No waiver of a breach of any portion of this contract shall constitute a waiver of continuing or future breach of such provision or of any other provisions hereof.
- These Terms and Conditions constitute the entire agreement of the parties. No amendments, changes, revisions or discharges hereof in whole or in part shall have any force or effect unless set forth in writing and signed by the parties hereto. This contract shall not be assignable by Buyer voluntarily by operation of law or otherwise without Seller's written consent.
- This contract shall be governed and shall be construed according to the domestic laws of the Commonwealth of Pennsylvania.
- Anything herein to the contrary notwithstanding, any action for alleged breach by Seller of the contract between the parties, including but not limited to any action for breach of the warranties herein set forth, shall be barred unless commenced by Buyer within one (1) year from the date such cause of action accrued.
- This agreement shall inure to the benefit of and be binding upon the parties hereto, their respective successors and permitted assigns.
- All notices required by this contract to be given by either party shall be sent in writing or by facsimile and shall be addressed to the last known address of such other party. Notices shall be deemed to have been received on the fifth business day following deposit in the mail.

VASTEX  
INTERNATIONAL

7 EMERY ST  
BETHLEHEM, PA. 18015 USA



## Vastex Warranty for V-2000HD Series Manual Printer

Doc#01-00-017 REV:A

Vastex, hereinafter referred to as “seller” warrants only to its “purchaser”, who holds a copy of the original invoice and is the original end user of the equipment in question, its new equipment against defects in workmanship on a pro-rated basis for a period of twenty five (25) years from the date of shipment to buyer and receipt of payment in full. Replacement parts are covered for a period of (1) year from ship date or for the remainder of the original 25 year warranty, whichever is longer, contingent on payment in full.

**This warranty is expressly contingent upon the buyer delivering to seller, at the address below, with all transportation charges prepaid, the part or parts claimed to be defective within the above mentioned period for new equipment and replacement parts. In order to expedite the movement of parts and to minimize down time to the buyer, the replacement part shall be supplied on a C.O.D. basis. If testing and analysis of said part by the seller or its supplier discloses that said part is defective, the cost of said part will be refunded to the buyer on a pro-rated basis.**

Except as otherwise provided herein, the equipment is being sold “as-is”. Final determination of the suitability of the equipment for the use contemplated by the buyer, is the sole responsibility of buyer, and seller shall have no responsibility in connection with the suitability.

All warranties implied by law, including the implied warranties of merchantability and fitness are hereby limited to workmanship and defective parts to a period of (25) years (for new equipment) and (1) year (for replacement parts) after date of shipment to first buyer. The express warranty and remedies contained herein and such implied limited warranties are made solely to the sole warranties and remedies and are in lieu of all other warranties, guarantees, agreements, and other liabilities, whether express or implied, and all other remedies for breach of warranty or any other liability of seller, in no event shall seller be liable for consequential damages.

Vastex will repair or replace any part of the original machine that is deemed defective or fails during the above mentioned time, due to poor workmanship, with the exception of gas springs and rubber mats. Examples of poor workmanship are welds, bearings, threads, knobs, fasteners, and general machine fatigue. The part must be shipped back to Vastex to be inspected at the shipper’s cost. If it is determined to be defective due to workmanship or normal wear, it will be repaired or replaced and shipped within 2 business days. The repaired part will be sent back ground carrier, freight prepaid if within 3 years of the original purchase and if in the continental US. After 3 years or if outside the continental US, parts will be shipped back per customers’ instructions, freight collect. If the exact part to be replaced is not available, a replacement part will be supplied that will perform within original design parameters.

No person, agent, distributor, or service representative is authorized to change, modify or extend the terms hereof in any manner whatsoever.

These terms and conditions are an essential part of the transaction between the parties and constitute the entire agreement between them with respect to the same.

Some states do not allow limitation on how long an implied warranty lasts of the exclusion or limitation of incidental, or consequential damages, so the above limitation may not apply to you.

This warranty gives you specific legal rights, and you may also have other rights which vary from state to state.

Please refer to doc. 01-01-006 for warranty implementation help.

Please refer to doc. 01-00-015 for specific terms and conditions of sale and the limited warranty.

This warranty effective as of 07/01/01

F:\Shared\Vastex\01-Manuals & Doc\00-misc\01-00-017 (V2000-HD Warranty).wpd

---

VASTEX  
INTERNATIONAL  
USA

---

7 EMERY STREET  
BETHLEHEM PA. 18015