

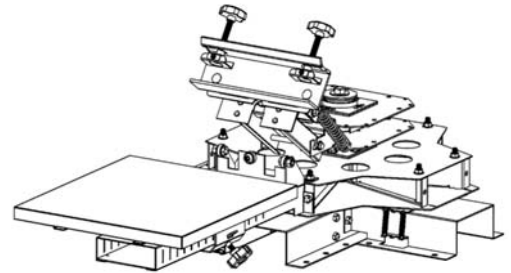

V-100
Machine Manual

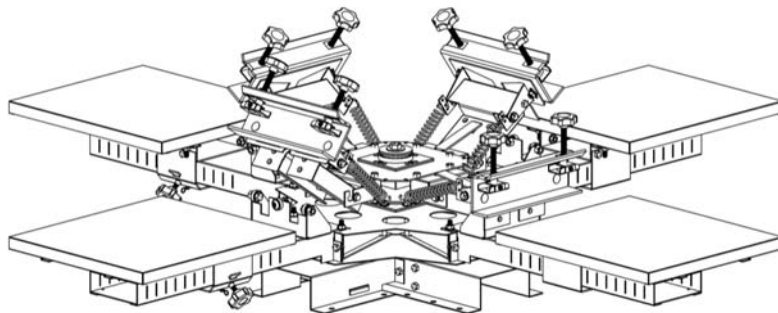

	Pg #
• Introduction / Safety / Features	2-3
• Stand Assembly	4-5
• Rotor Hub Assembly	6
• C-Hub Assembly	7
• Center Assembly	8
• Rotor Arm Assembly	9
• Pallet Assembly	10-11
• Print Head Assembly	12-13
• Machine Adjustments	14
• Warranty	15

Vastex International, Inc.
 7 Emery Street
 Bethlehem, PA 18015
 Phone# 610 625-2702 Fax# 610 625-2775
 Web Site www.vastex.com

Authorized Representative in Europe:
 Certification Experts BV
 Nieuwstad 100 1381 CE Weesp,
 The Netherlands
 Tel : + 31 (0) 294 – 48 33 55
 Fax : + 31 (0) 294 – 41 46 87

Vastex E-mail assistance

Purchasing & Product Info:
sales@vastex.com
 Electrical Support:
stech@vastex.com
 Tech Support, Mechanical Setup, and Operation:
techsupport@vastex.com
 Screen Printing Issues & Support:
printech@vastex.com

Serial Number: VTX_____ Date: ___/___/___

(Please log your machine's serial number and date of purchase for future reference.)

Introduction

Thank you for purchasing your printing equipment from Vastex International Inc.

Vastex has been designing and building printing equipment since 1960. We have knowledge and experience, and are proud to supply the printing industry with quality equipment at an affordable price. You can be confident your purchase will give you years of trouble free service.

Safety

Intended Use:

This equipment is intended for performing manual screen printing of fabric items, particularly garments. This equipment must not be used in a manner contrary to what is described in this manual.

Safety:

- The operator should read and understand this manual before operating this equipment. Store manual and safety information near equipment for easy access to operators.
- Keep children and pets clear of the work area.
- Do not sit or stand on printer.
- The print heads utilize heavy duty springs to hold the screen in the raised position. These springs generate a lot of force. Care must be taken when installing and removing the print head lifting springs.
- Do not operate printer without print head stop bar in place.
- Do not allow print heads to swing into their raised position unrestrained.

Features

- Steel Pallets
- Floating Print heads allows multiple heads down
- Available up to 4 table color
- Expandable from 1x1 to 4x4

Tools Required

- 1/2", 5/16", 3/4" Wrenches.
- **OR METRIC:** 8mm, 13mm, 19mm.

Stability during use, transportation, assembly, foreseeable breakdowns, etc.:

This equipment is designed and expected to be stable during all normal conditions of use.

- When assembling your press, do not stand tall parts upright until you are ready to install them; lay them flat instead.
- It is recommended that assembly should be done by two or more people, to facilitate the alignment of parts that must be bolted together.
- If one or more legs of the press will be removed, be certain to adequately support the rest of the press.

Safe handling, transport, and storage of the press:

Your press is designed to be inherently safe under all normal conditions. When handling or transporting your press, be aware of the weight of your unit and have an appropriate number of people to lift the weight safely:

V100-11: 65lb (29.5kg) V100-44: 132lb (59.9kg)

Placing this equipment into service:

To place your press into service —

- 1.) Follow the assembly instructions on pages 4 through 12.

Operating this equipment:

To operate your press —

- 1.) Clamp your first screen into head #1.
- 2.) Repeat for additional screens, using additional heads.
- 3.) Place garment in pallet #1.
- 4.) Lower print head and squeegee ink through screen.
- 5.) Raise print head. For one-color printing, load new, blank garment and repeat steps above.
- 6.) For multi-color printing, rotate the pallet to print head #2 and repeat steps above until all colors are printed.
- 7.) If any adjustments to the print heads need to be made, refer to the instructions in this manual.

In the event of an accident or breakdown:

In the unlikely event that a part of your press breaks, or if your press does not seem to be operating normally and the instructions in this manual do not correct the issue, do not continue using your press. Contact Vastex for assistance in repairing your press.

Safety during maintenance or while making adjustments:

- When cleaning or lubricating your press, make sure that nobody in the work area is close enough to cause any part of the press to move unexpectedly.
- Do not remove springs unless under the specific direction of Vastex customer service.
- Observe the general safety cautions on page 2 of this manual.

Stand Assembly

1) Line up Notches

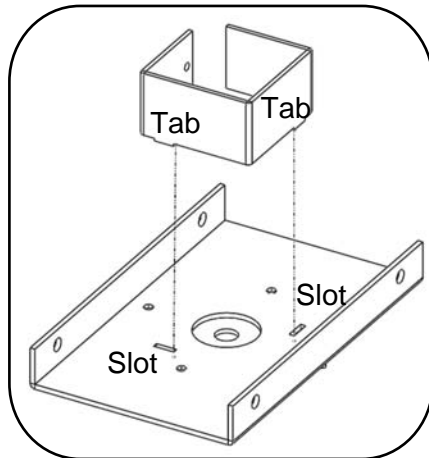

2) Install and Leave Loose

-(4) 5/16-18 x 3/4" Bolts

-(4) 5/16-18 Lock Nuts

Do not tighten until STEP 5

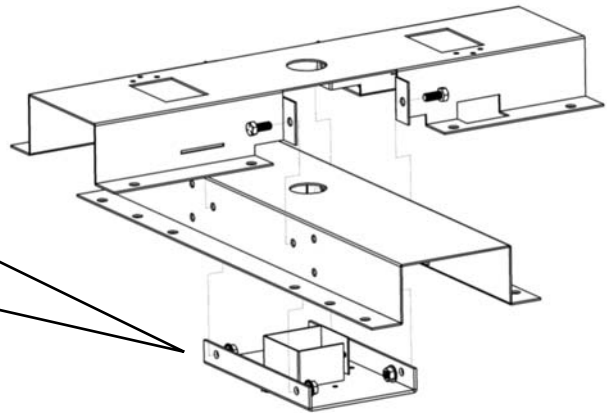

3) Wiggle shaft back and forth to insert. Very tight fit.

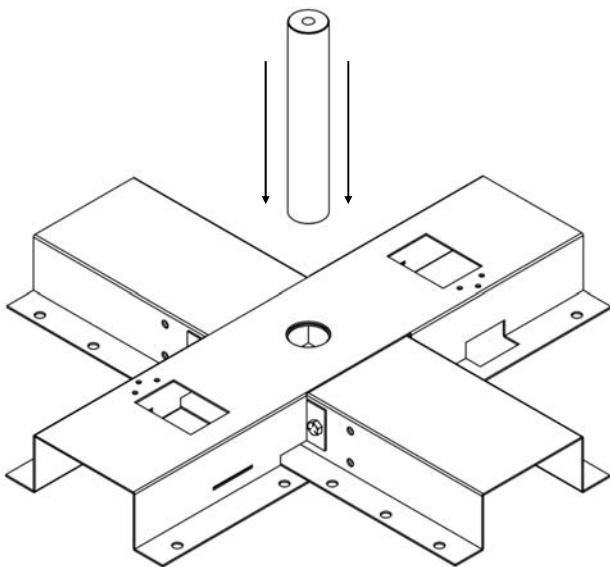

4) Install and Tighten

-(1) 1/2-13 x 1.0" Bolt

-(1) 1/2" Lock Washer

Use 3/4" or adjustable wrench

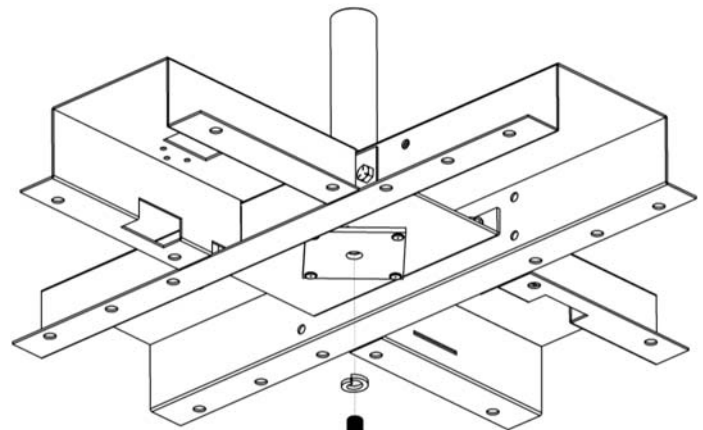

5) Tighten hardware from step 2 using 1/2" or 13mm wrench.

6) Install and Tighten (2) stand braces with

-(4) 5/16-18 x 1/2" Bolts

-(4) 5/16-18 Lock Nuts

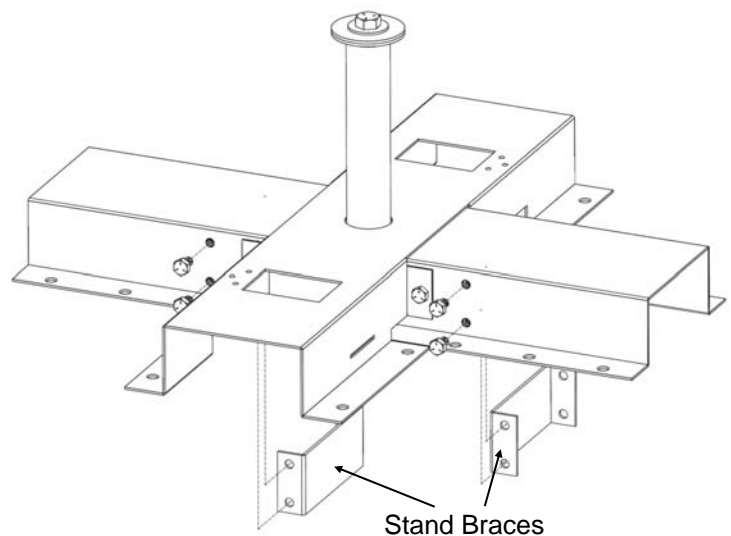

Detent Installation

1) Install (2) Detent Assemblies

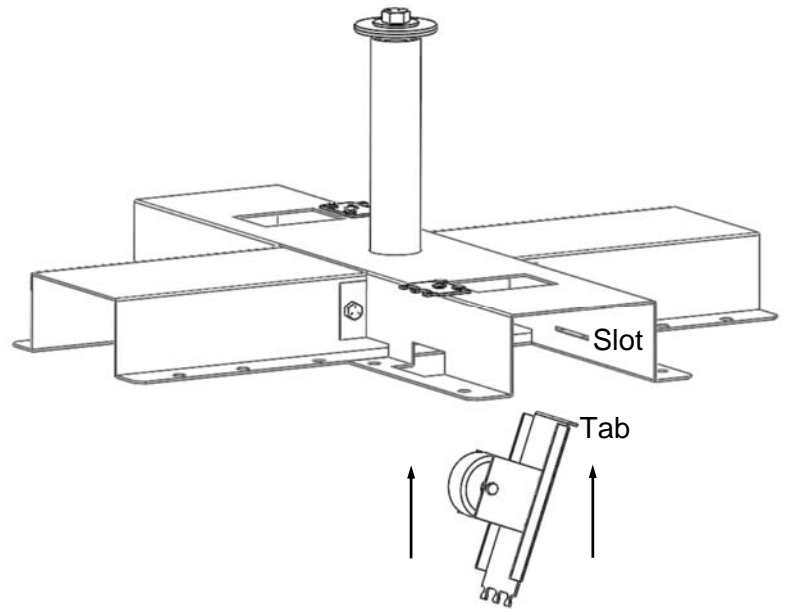

2) Insert tab into slot in base.
Rotate into position.

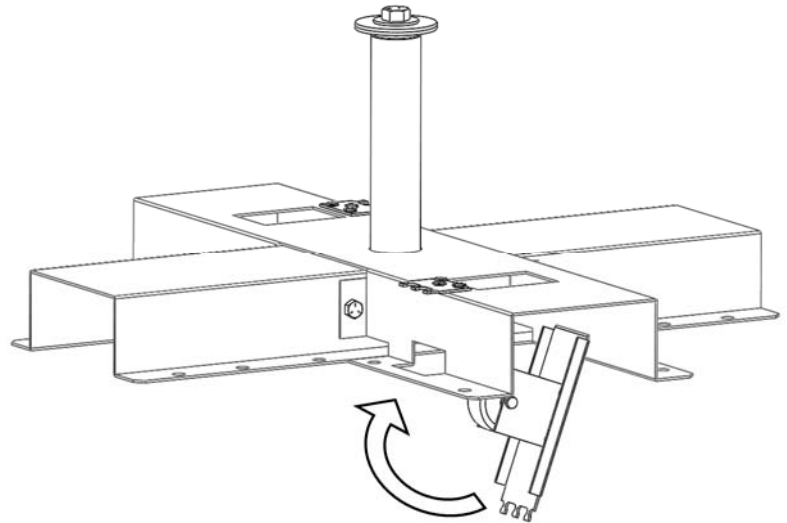

3) Install 2 springs per Detent

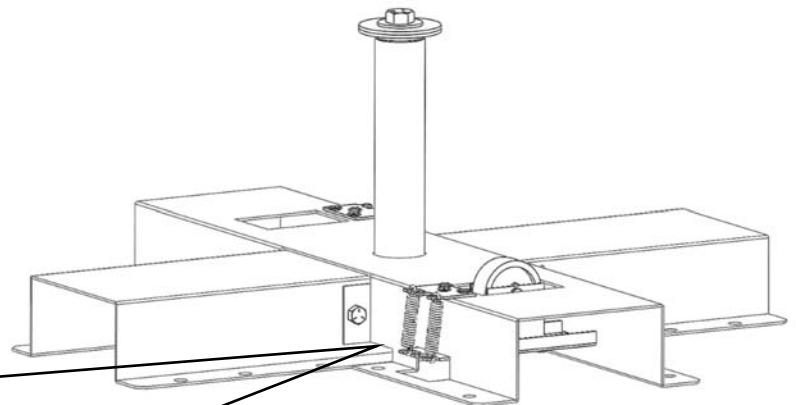
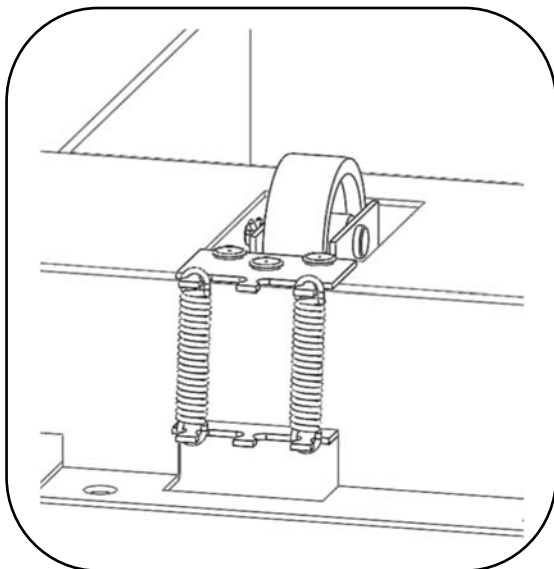

Rotor Hub Assembly

- 1) Install and Leave Loose**
-(8) 5/16-18 x 3.0" Bolts
-(8) 5/16-18 Lock Nuts

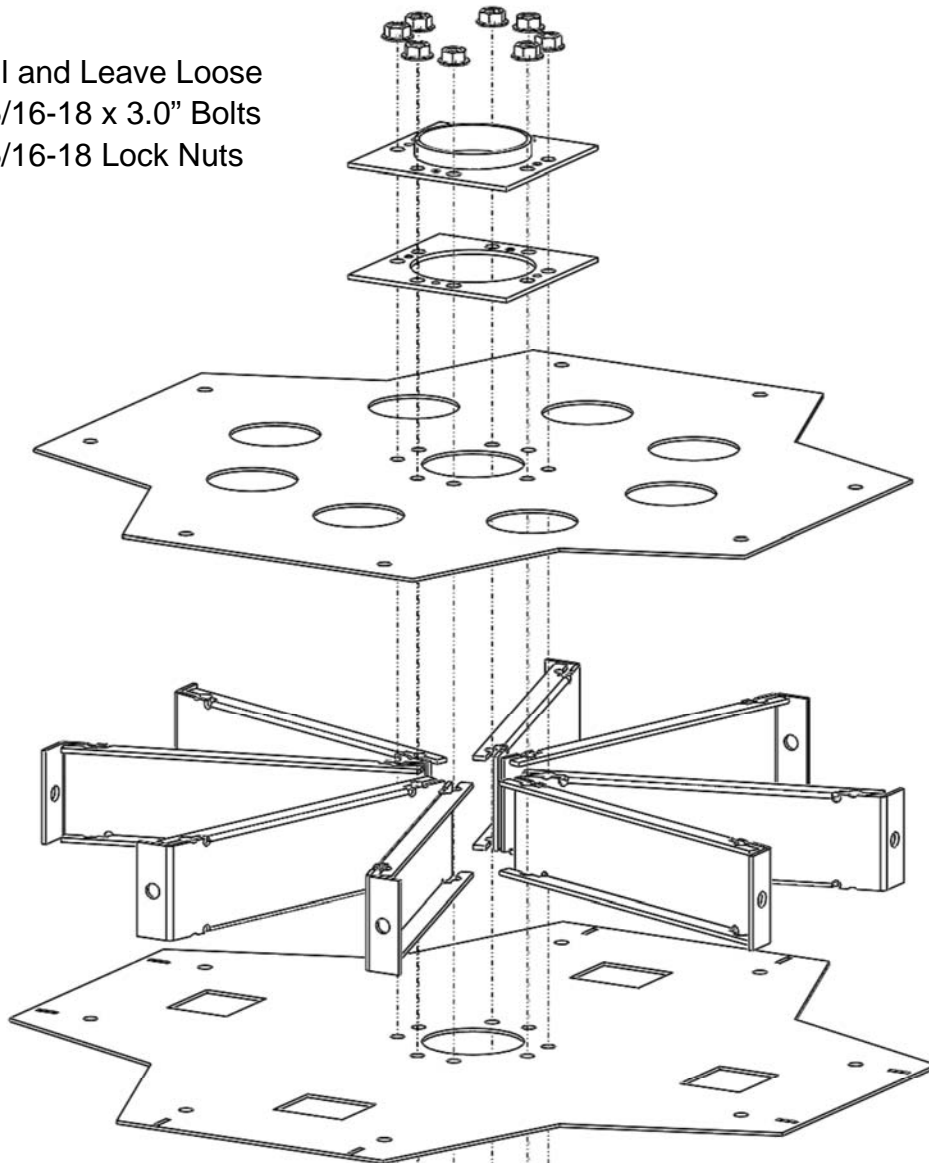

- 2) Install and leave loose**
-(8) 5/16-18 x 3.0" bolts
-(8) 5/16-18 lock nuts
For 1 station, tighten 3 sets.
For 4 station, leave all outer bolts loose.
Using 1/2" or 13mm Wrench

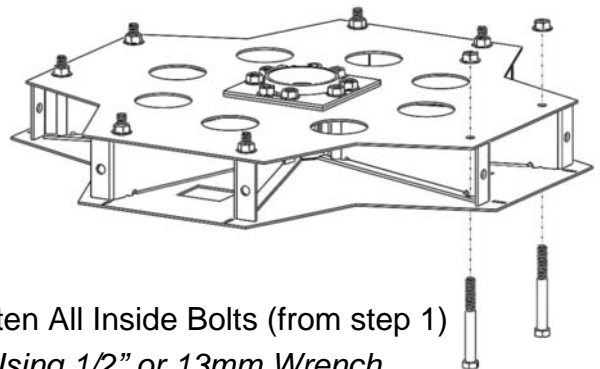
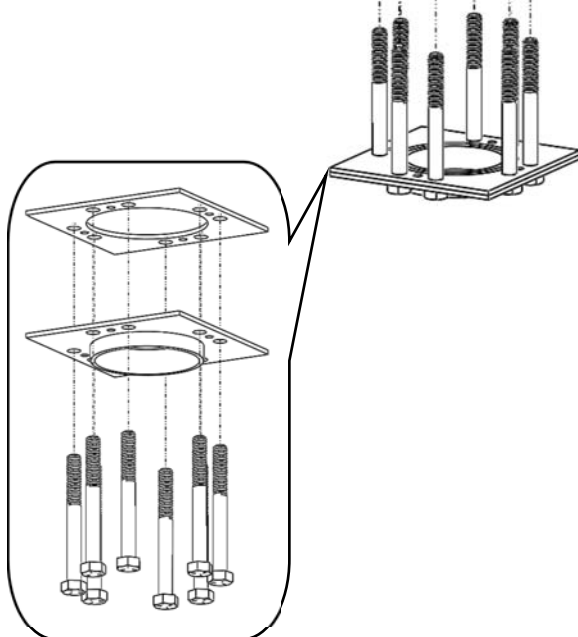

- 3) Tighten All Inside Bolts (from step 1)**
Using 1/2" or 13mm Wrench

C-Hub Assembly

1) Install and Leave Loose

-(2) 5/16-18 x 2-1/4" Bolts

-(2) 5/16-18 Lock Nuts

Install all included hinges at this time

**Do Not Tighten until
Hub Installation Step 3**

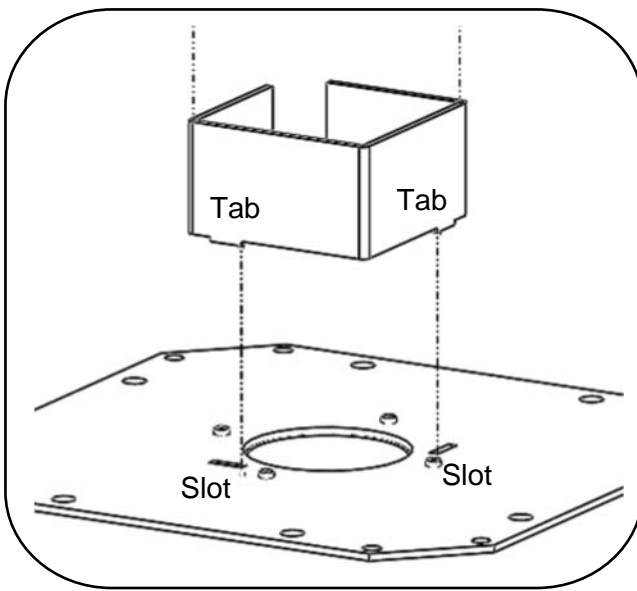
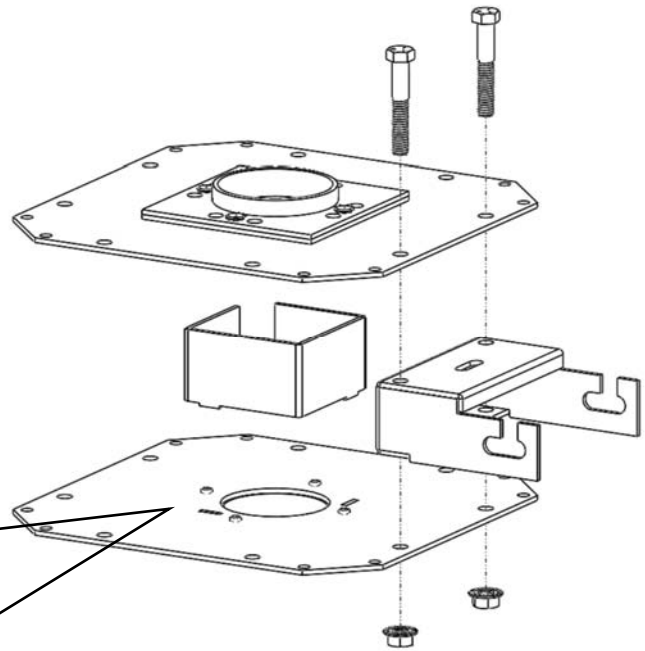

1 color Hub Shown Below

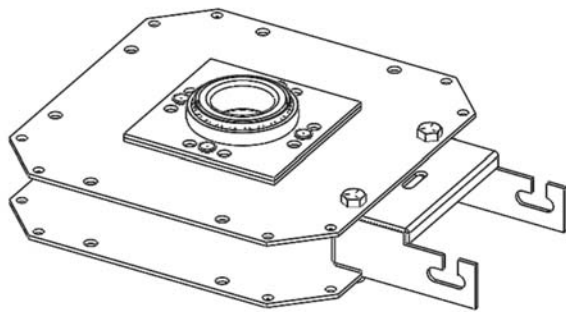

4 color Hub Shown Below

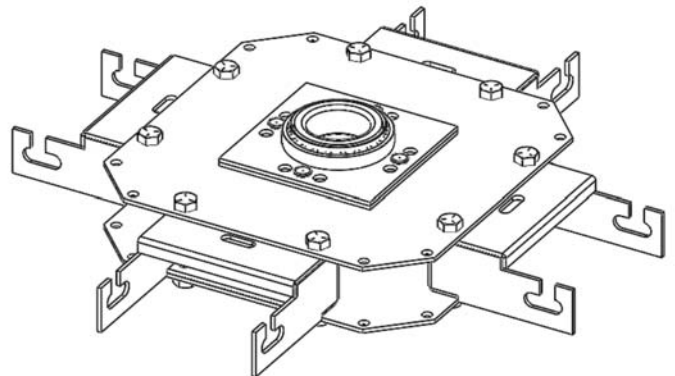

Hub Installation

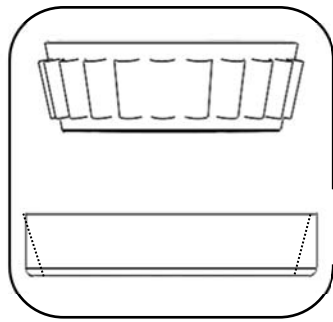

- 1) Bearings can only be installed in one direction, They must fit into the Bearing Race in each Hub.

NOTE: Assembly shows 4 hinges on C-Hub. Your assembly may have from 1 to 4 Hinges depending on machine specs.

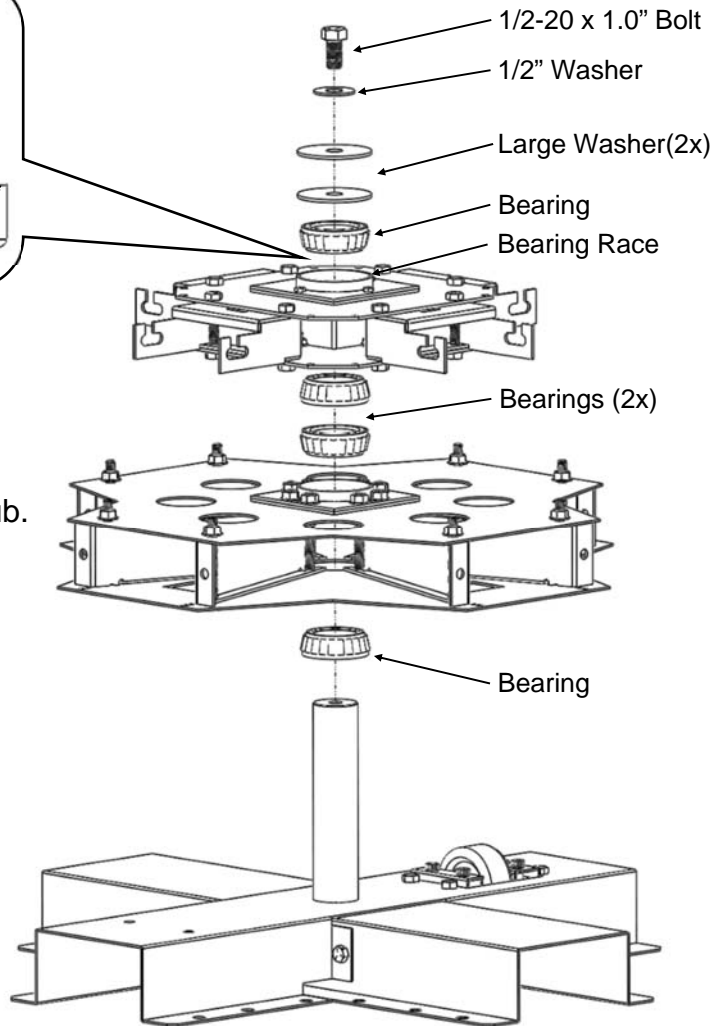

- 2) Tighten top 1/2-20 x 1.0" Bolt using a 3/4" or 19mm open end wrench. Do not Over Tighten. Only tighten until there is drag on the hubs when spinning each hub individually. If machine does not spin easily, loosen this bolt in 1/8 turn increments until desired feel is achieved.

- 3) Tighten all Hinge bolts that were installed in **C-Hub Assembly Step2** (circled on right) using 1/2" or 13mm Wrench.

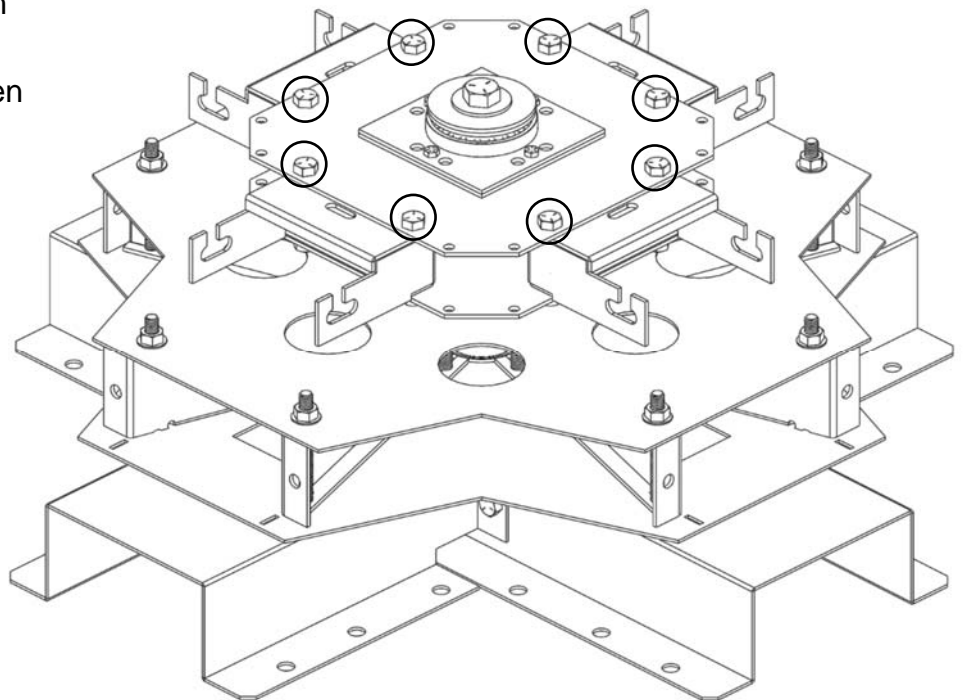

Rotor Arm Installation

1) Install and tighten

- (4) 5/16-18 x 1/2" Bolts
- (4) 5/16-18 Lock Nuts

Using 1/2" or 13mm Wrench

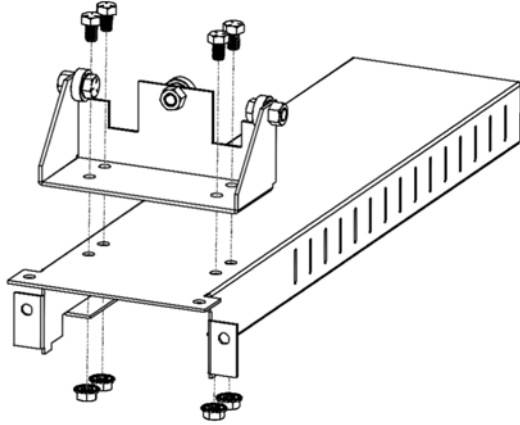

2) Remove

- (2) 5/16-18 Nuts for each Rotor Arm to be installed.

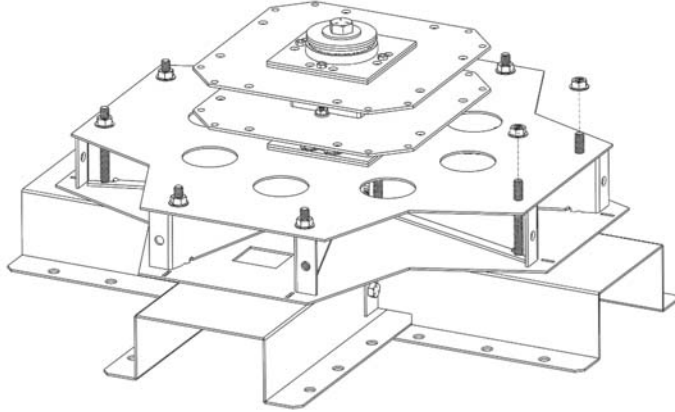

3) Align Rotor Arm with Bolts in Rotor Hub. Tabs on bottom of Rotor Arm drop into slots in Bottom Rotor Hub Plate.

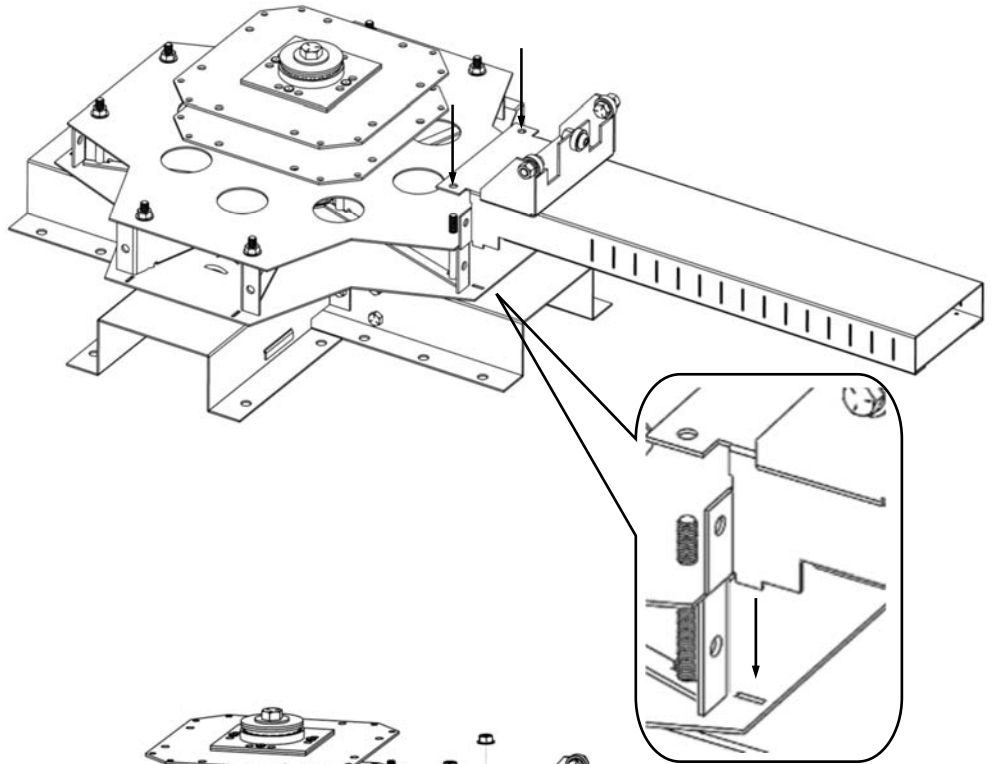

4) Install and Tighten

- (4) 5/16-18 Lock Nuts
- (2) 5/16-18 x 1/2" Bolts

Using 1/2" or 13mm Wrench

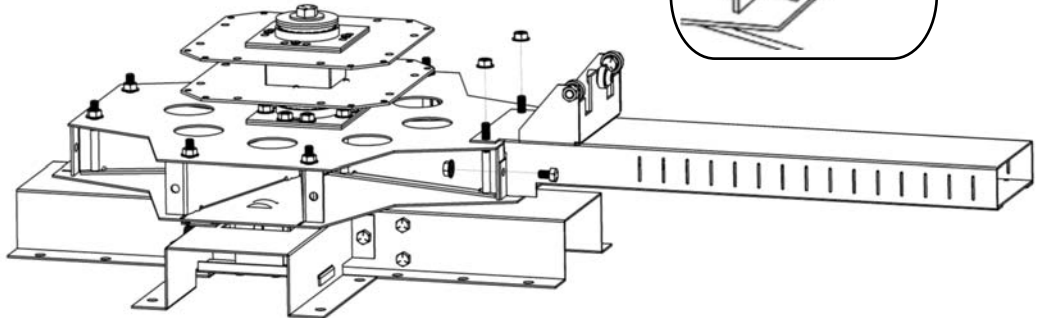

5) Install additional Rotor Arms by repeating steps 1-4.

Tighten all remaining 5/16-18 Lock Nuts with 1/2" or 13mm wrench

Pallet Assembly

1) Install and Tighten

- (4) 5/16-18 x 1/2" Bolts
- (4) 5/16-18 Lock Nuts

Using 1/2" or 13mm wrench

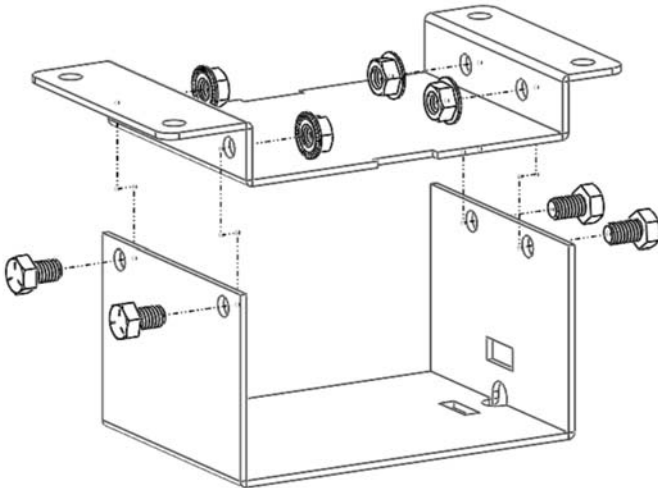

2) Install

- (1) 5/16-18 T Weldnut
- (1) Pallet Arm knob

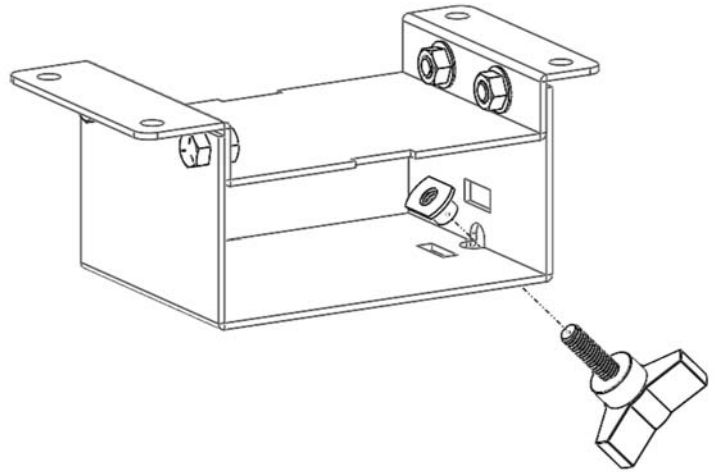

3) Insert Corner Clamp Bracket

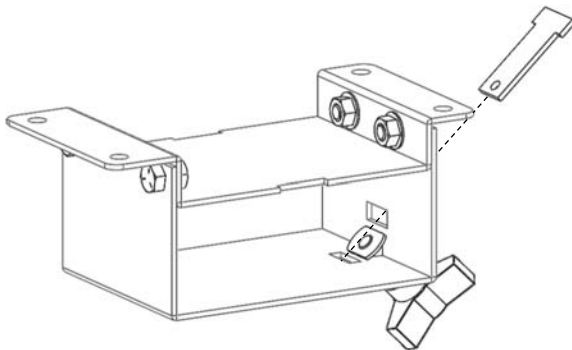

4) Install Angel Clip

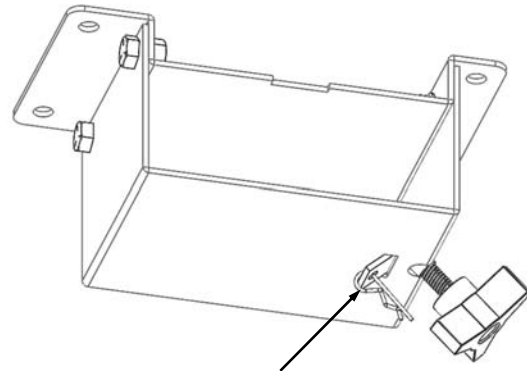

5) Install

- (4) 5/16-18 x 1.0" Square head Bolts

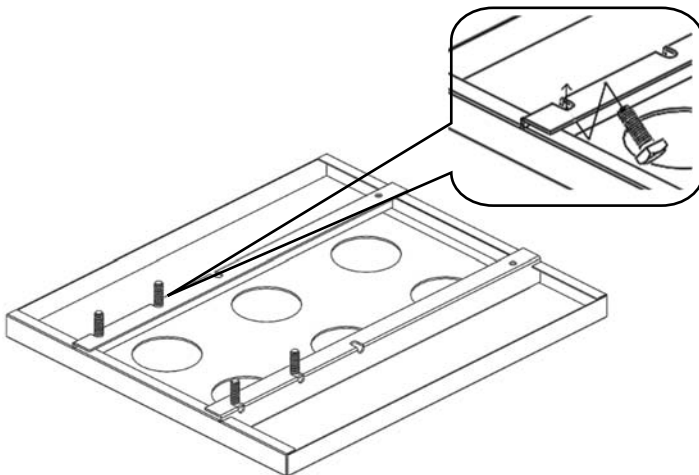

6) Install and Tighten

- (1) Assembled Pallet Arm
- (4) 5/16-18 Lock nuts

Using 1/2" or 13mm wrench

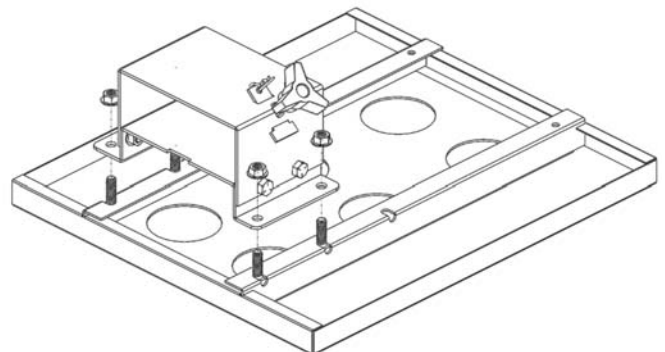

Pallet Installation

1) Slide your assembled Pallet and Pallet Arm onto Rotor Arm.

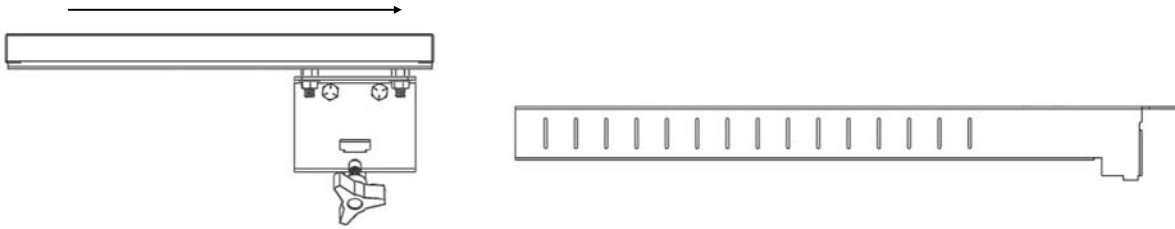

2) Set each pallet the same. Use slots on side of Rotor Arm for reference.

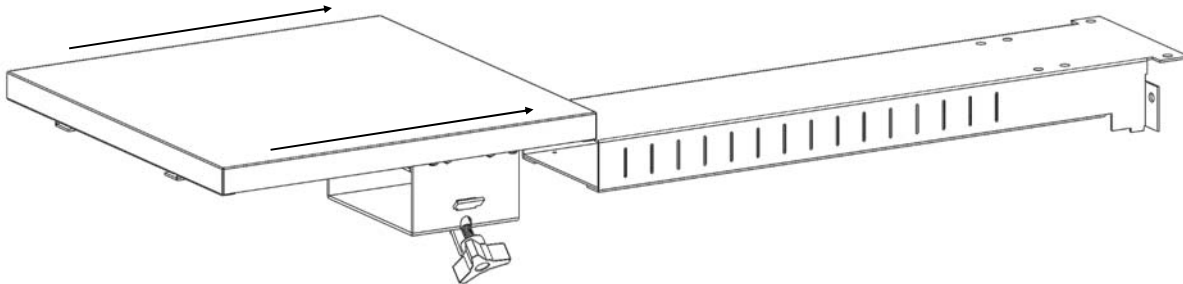

3) Tighten knob on Pallet Arm. Do not over tighten.

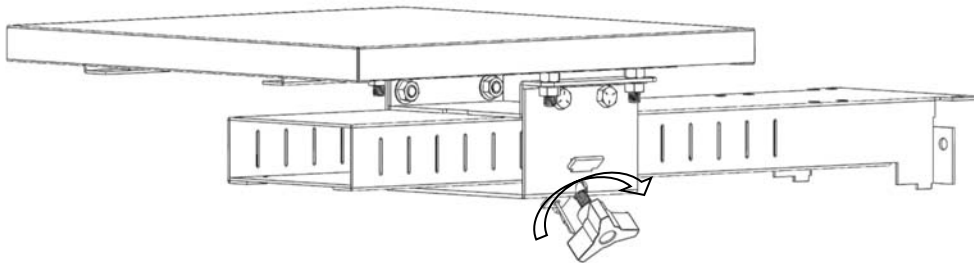

Print Head Assembly

1) Install and Tighten

- (4) 5/16-18 x 3/4" Bolts
 - (2) 5/16 Flat Washers
 - (2) Double 5/16-18 Nuts
 - (1) Screen Clamp Mount
- Using 1/2" or 13mm Wrench*

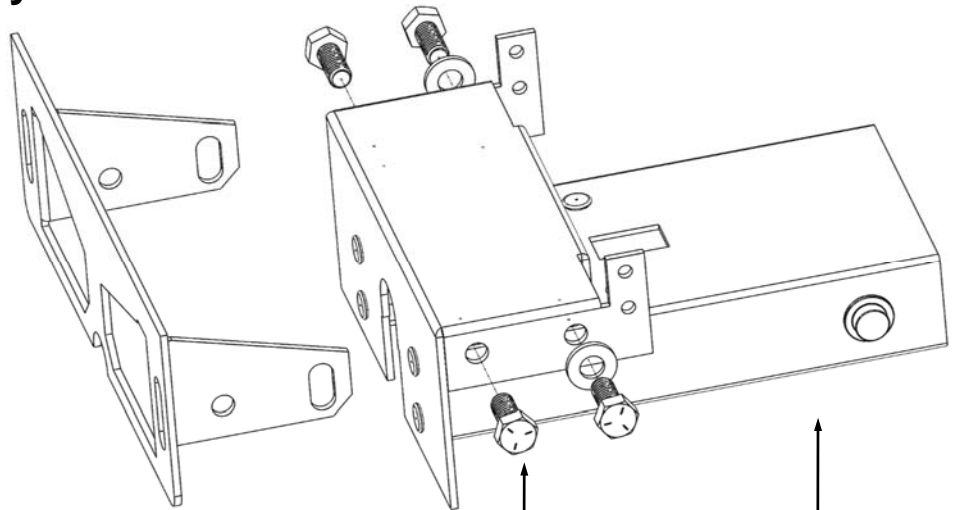

Double 5/16-18 Nuts
(see Hardware Identification)

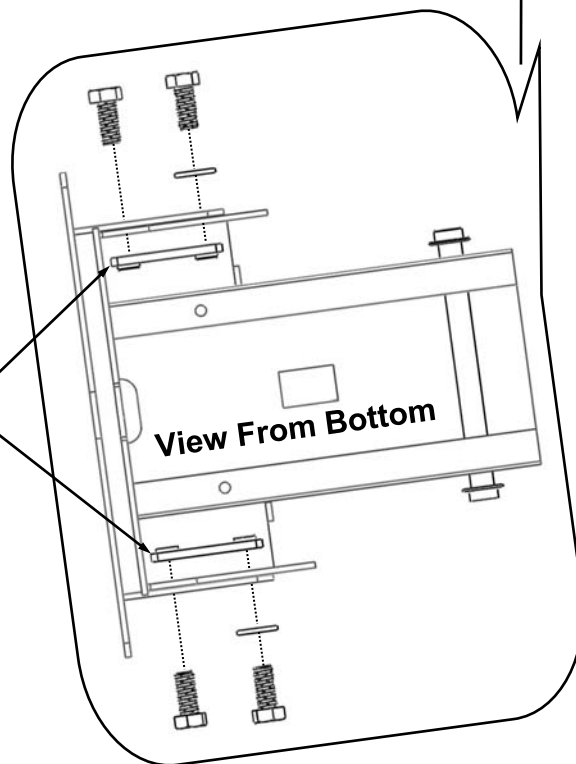

2) Install and Tighten

- (2) 5/16-18 x 3/4" Carriage Bolts
 - (2) 5/16 Flat Washers
 - (2) 5/16-18 Lock Nuts
 - (1) Assembled Screen Clamp
- Using 1/2" or 13mm Wrench*

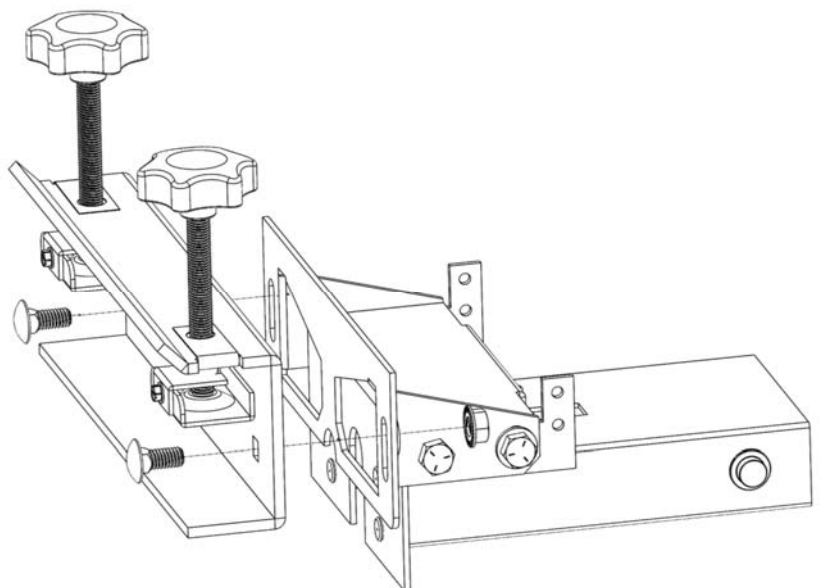

— Print Head Installation —

— Note Spring Location Options/Orientation

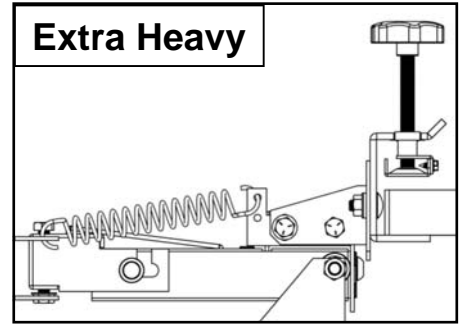
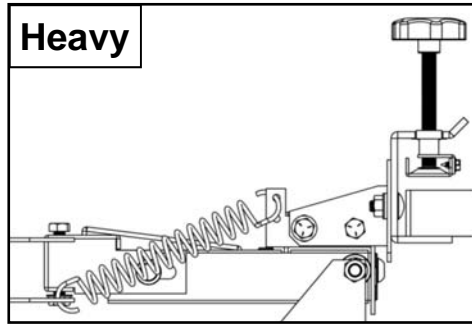
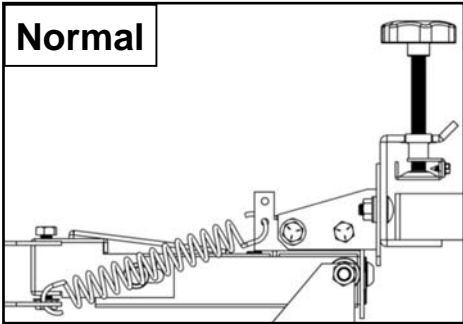

1) Install Print heads as shown.

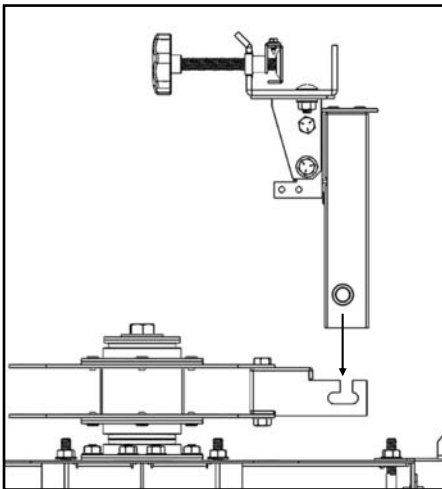

2) Attach Springs

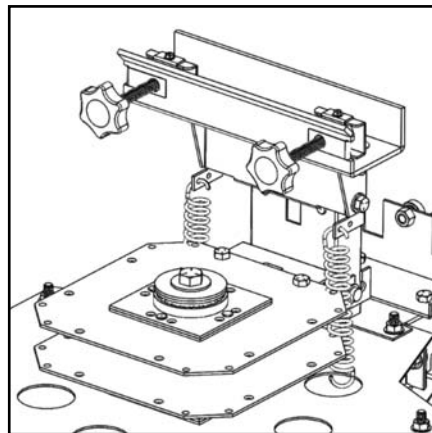

3) Attach Springs

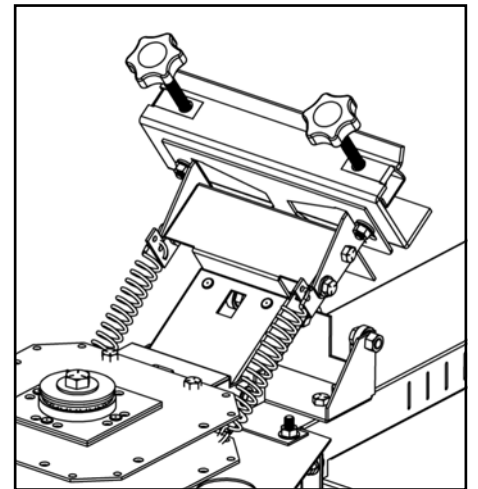

4) Install Stop Bar as shown. Stop Bar must be installed while head is in the Down position.

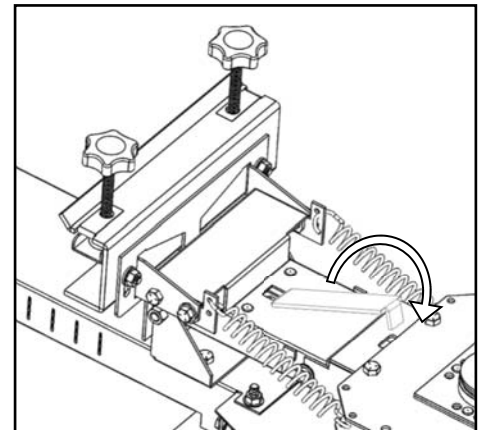
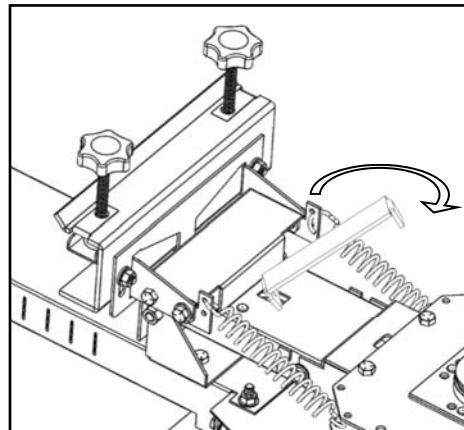
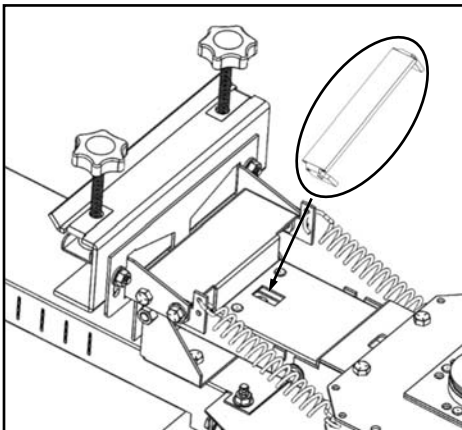

Machine Adjustments

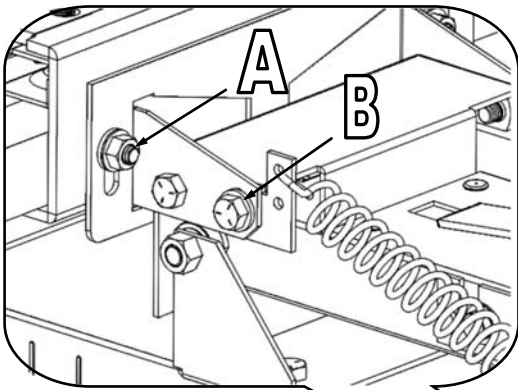

A To Adjust Screen Height and angle Left to Right. Loosen (1) Nut (Marked A) Slightly and Set Screen Level. Adjust one side at a time.

1/2" or 13mm Wrench needed.

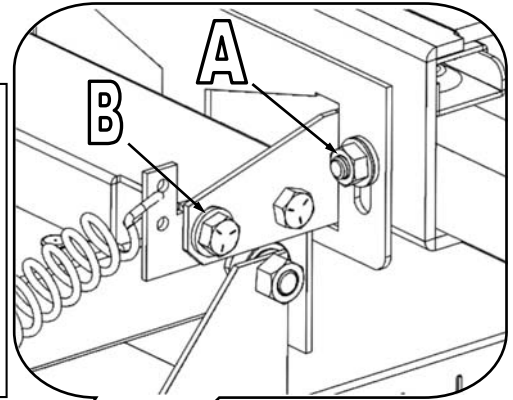

B To Adjust Screen angle Front to Back. Loosen (2) Bolts (Marked B) Slightly and Set Screen Level.

1/2" or 13mm Wrench needed.

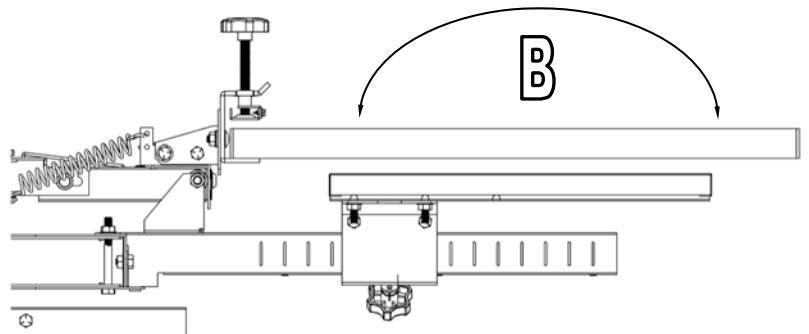
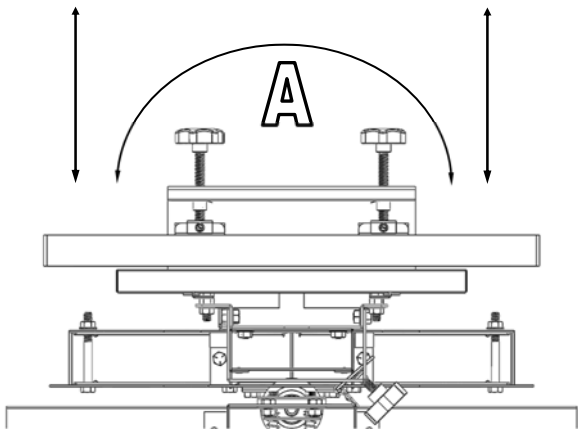
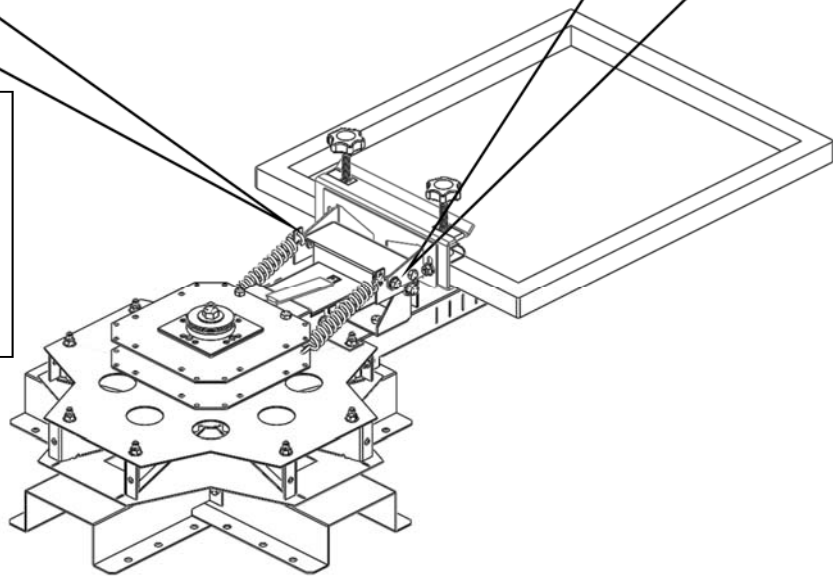

Vastex Warranty

Doc#01-00-005D Revised 2/20/2018

(1.) Vastex, hereinafter referred to as "seller" warrants only to its original "purchaser", who holds a copy of the original invoice and is the original end user of the equipment in question, its new equipment against manufacturer defects in materials or workmanship on a pro-rated basis. Warranty period begins from date of shipment to the buyer and will only apply to customers paid in full. Warranty periods are as follows: one (1) year for E-1000, three (3) years for all other complete machines (including F-Flash), fifteen (15) years for infrared heaters (excluding F-Flash) installed by Vastex in a new dryer, three (3) years for replacement infrared heaters, and one (1) year for replacement parts. Rubber blankets, light bulbs and glass on exposure units are particularly subject to wear while in use. Wear is not covered by this warranty but as stated above only manufacturers defects are covered. All sales made through Vastex dealers must be certified by that dealer before a warranty replacement is issued. All equipment is thoroughly tested and inspected before packaging. This warranty does not cover minor cosmetic damages that occur during shipment that do not affect the functionality of the equipment.

(2.) **This warranty is expressly contingent upon the buyer delivering to seller, at the address below, with all transportation charges prepaid, the part or parts claimed to be defective within the above mentioned warranty periods stated in paragraph one. The defective part or parts will be repaired or replaced at the discretion of Vastex International, Inc. If the equipment in question is less than one (1) year old, it will be shipped to the customer at no charge, with an RGA issued by Vastex for the defective part. The defective part must be shipped back to Vastex freight prepaid within 30 days or the account will be billed. If the equipment is more than a year old, the part will be shipped after we receive the defective part. If it's necessary to expedite the movement of parts and to minimize down time to the buyer, the replacement part shall be supplied on a C.O.D. basis. If testing and analysis of said part by the seller or its supplier discloses that said part is defective, the cost of said part will be refunded to the buyer on a prorated basis.**

(3.) Except as otherwise provided herein, the equipment is being sold "as-is". Final determination of the suitability of the equipment for the use contemplated by the buyer, is the sole responsibility of buyer, and seller shall have no responsibility in connection with the suitability.

(4.) All warranties implied by law, including the implied warranties of merchantability and fitness are hereby limited to manufacturer defects in materials or workmanship during the warranty period stated in paragraph one. The express warranty and remedies contained herein and such implied limited warranties are made solely to the sole warranties and remedies and are in lieu of all other warranties, guarantees, agreements, and other liabilities, whether express or implied, and all other remedies for breach of warranty or any other liability of seller, in no event shall seller be liable for consequential damages.

No person, agent, distributor, or service representative is authorized to change, modify or extend the terms hereof in any manner whatsoever.

These terms and conditions are an essential part of the transaction between the parties and constitute the entire agreement between them with respect to the same.

Some states do not allow limitation on how long an implied warranty lasts of the exclusion or limitation of incidental, or consequential damages, so the above limitation may not apply to you.

This warranty gives you specific legal rights, and you may also have other rights which vary from state to state.

Infrared heaters are the only replacement parts covered for a period of (3) years from date of shipment and contingent to receipt of payment in full.

Electrical components cannot be returned once installed unless proven defective.

Please refer to doc. 01-00-015 for specific terms and conditions of sale and the limited warranty.

Please refer to doc. 01-00-017 for V-2000HD printer warranty.

Updates: V1000 to 3 year warranty 01/09/12, Heater warranty to 15 years 01/02/2012.

TERMS AND CONDITIONS OF SALE AND LIMITED WARRANTY Doc.#01-00-015

- Buyer's order will constitute an offer in accordance with the terms hereof and such offer, upon acknowledgment of Seller, will constitute the agreement between Buyer and Seller. Buyer's order after such acknowledgment by Seller will not be subject to cancellation, change or reduction in amount, or suspension by Buyer of deliveries, unless prior to such action Buyer has obtained Seller's written consent. Notwithstanding anything to the contrary in Buyer's Purchase Order or other communications, the parties agree to be bound by these Terms and Conditions. Acceptance of the product by the Buyer shall be deemed to constitute unconditional acceptance of these Terms and Conditions.
- Any of these terms, conditions and provisions of Buyer's order which are inconsistent with Seller's acknowledgment and these Terms and Conditions of Sale shall not be binding on the Seller and shall be considered not applicable to any sale so made. No waiver, alteration or modification of any of the provisions on either side of the document shall be binding upon Seller unless agreed to in writing by Seller.
- (a) All prices are F.O.B. Seller's Plant and method of delivery and routing shall be at Seller's discretion, unless specifically otherwise stated herein. Notwithstanding any agreement to pay freight, delivery of products purchased hereunder to a common carrier or licensed trucker shall constitute delivery to Buyer and be determinative of the date and time of shipment and all risk of loss or damage in transit shall be borne by Buyer. If the Buyer fails to accept the goods from the common carrier or licensed trucker, the Seller shall be entitled to claim payment from the Buyer. Seller shall arrange for storage, the risk and the cost, including insurance costs, to be borne by the Buyer (and Buyer agrees to pay such amounts upon demand) except if the failure to accept delivery is due to any of the exceptions noted in Paragraph 4.
(b) Terms of payment shall be as stated on invoice.
- It is understood that deliveries will be made in accordance with Seller's regular production schedule. Every reasonable effort will be made to meet the Buyer's required delivery dates but Seller will not be liable for damages or be deemed to be in default by reason of any failure to deliver or delay in delivery due to any preference, priority, allocation or allotment order issued by the Government, whether Federal, State or local, or causes beyond its control including but not limited to, Acts of God or a public enemy, acts of Government, fires, floods, epidemics, quarantine restrictions, strikes, lockouts, freight embargoes, severe weather, unavailability of materials or shipping space, delays of carriers or suppliers or delays of any subcontractors. Should delay in delivery be caused by any of the circumstances mentioned in this paragraph, such extension of the delivery period shall be granted as is reasonable under the circumstances of the case. Should delay be caused by an event not specifically mentioned in this paragraph, damages will be limited to cancellation of the purchase order without penalty, and refund of any monies deposited or prepaid on the purchase order with no liability for any consequential or incidental damages.
- Seller reserves the right to increase the prices prior to Seller's acceptance of order and/or after expiration of any price quoted by Seller.
- Unless otherwise stated in writing, Seller's prices do not include sales, excise, value-added or other taxes. Consequently, in addition to the price specified herein, the amount of any present or future sales, use, excise, value-added or other tax applicable to the manufacture, sale, purchase or use of the products hereunder shall be paid by Buyer, or in lieu thereof, Buyer shall provide Seller with a valid tax exemption certificate acceptable to the taxing authorities.
- Seller reserves the right, at any time, to revoke any credit extended to Buyer because of Buyer's failure to pay for any products when due or for any other reason deemed good and sufficient by Seller and in such event, all subsequent shipments shall be paid for prior to at delivery at Seller's option.
- (a) SELLER'S LIABILITY SHALL BE LIMITED TO SELLER'S STATED SELLING PRICE PER UNIT OF ANY DEFECTIVE GOODS AND SHALL IN NO EVENT INCLUDE BUYER'S MANUFACTURING COSTS, LOST PROFITS, GOODWILL, OR ANY OTHER SPECIAL, INDIRECT, INCIDENTAL OR CONSEQUENTIAL DAMAGES, ARISING OUT OF THE AGREEMENT, THIS CONTRACT, THE SALE OF THE PRODUCTS TO THE BUYER OR THE USE OR THE PERFORMANCE OF THE PRODUCTS. Seller may at its discretion repair, replace or give the Buyer credit (pro-rated) for such defective products.
(b) Notwithstanding anything herein to the contrary, Seller shall have no liability for alleged defects with the products which are not specified in written notice from the Buyer to the Seller within thirty-six (36) months from the date of shipment of machines. Seller shall pass to Buyer any warranty received by Seller from the manufacturer of Limited Life Components, which in most cases is 12 to 18 months.
(c) Seller shall have no liability under this Limited Warranty unless Buyer has paid in full for the products. Further, this Limited Warranty is expressly contingent on Buyer's delivery to Seller, all costs prepaid, the defective part(s) within thirty-six (36) months of shipment to Buyer, together with a written statement specifying the alleged defect(s). Any replacement part(s) shall be shipped to Buyer on a C.O.D. basis.
(d) SELLER SPECIFICALLY EXCLUDES ALL WARRANTIES, EXPRESSED, IMPLIED OR OTHERWISE, EXCEPT AS STATED EXPLICITLY IN THESE TERMS AND CONDITIONS OF SALE. SELLER DISCLAIMS THE WARRANTY OF MERCHANTABILITY AND FITNESS FOR A PARTICULAR PURPOSE.
- The remedies herein reserved by Seller shall be cumulative and in addition to any other legal remedies. No waiver of a breach of any portion of this contract shall constitute a waiver of continuing or future breach of such provision or of any other provisions hereof.
- These Terms and Conditions constitute the entire agreement of the parties. No amendments, changes, revisions or discharges hereof in whole or in part shall have any force or effect unless set forth in writing and signed by the parties hereto. This contract shall not be assignable by Buyer voluntarily by operation of law or otherwise without Seller's written consent.
- This contract shall be governed and shall be construed according to the domestic laws of the Commonwealth of Pennsylvania.
- Anything herein to the contrary notwithstanding, any action for alleged breach by Seller of the contract between the parties, including but not limited to any action for breach of the warranties herein set forth, shall be barred unless commenced by Buyer within one (1) year from the date such cause of action accrued.
- This agreement shall inure to the benefit of and be binding upon the parties hereto, their respective successors and permitted assigns.
- All notices required by this contract to be given by either party shall be sent in writing or by facsimile and shall be addressed to the last known address of such other party. Notices shall be deemed to have been received on the fifth business day following deposit in the mail.**