

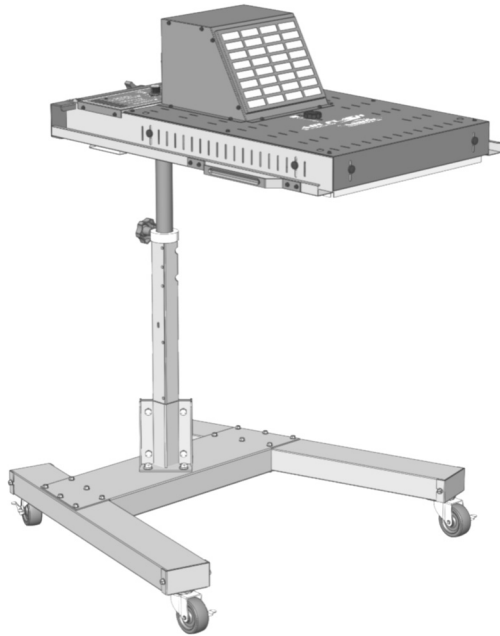

RedFlash and AirFlash Manual

Assembly and Operating Instructions



Contents

	Pg#
• Electrical Requirements	2
• Safety Information	3
• Assembly and Installation	4-7
• Operation and Controls	8
• Maintenance/Troubleshooting	9
• 01-00-005 Warranty	10
• CE Declaration	11

Vastex International, Inc.
 7 Emery St
 Bethlehem, Pa. 18015-1982 USA
 Phone# 610 625-2702 Fax# 610 625-2775
 Web Site www.vastex.com

Authorized Representative in Europe:
 Certification Experts BV
 Nieuwstad 100 1381 CE Weesp,
 The Netherlands
 Tel : + 31 (0) 294 – 48 33 55
 Fax : + 31 (0) 294 – 41 46 87

Vastex E-mail assistance

Purchasing & Product Info:
sales@vastex.com

Electrical Support:
stech@vastex.com

Tech Support, Mechanical Setup, and Operation:
techsupport@vastex.com

Screen Printing Issues & Support:
printech@vastex.com

Electrical Drawing #: _____ Rev: _____

Serial #: VTX- _____ Date: ____/____/____

(Please log your machine's serial number and date of purchase for future reference.)

— Placing your equipment into service

This manual contains assembly and operating instructions for the RedFlash and AirFlash. Refer to page 4 of this manual to determine the electrical requirements for your product. Ensure that your electrical supply matches the requirements of your unit; if it does not, consult a licensed electrician for assistance.

- 1.) Begin by assembling your unit's stand. See page 5&6 of this manual if you are unsure which stand type you have (standard or SHHD heavy-duty). Follow the standard stand assembly directions on page 6, or the heavy-duty stand assembly instructions on page 5, as appropriate to your stand.
- 2.) Assemble your head unit onto your saddle as shown on page 7.
- 3.) If you own an AutoFlash model, please refer to manual 01-03-038_Autoflash_Manual

— Instructions for use of this equipment

For RedFlash and AirFlash models: follow the instructions on page 8 of this manual.

— Stability during use, transportation, assembly, testing, and foreseeable breakdowns

This equipment is designed and expected to be stable during all foreseeable conditions, provided that the safety information and instructions in this manual are followed. Do not place any objects on machine heads. If it is necessary to remove the column from the stand, lay the saddle/head assembly flat on the ground — do not try to balance it upright.

— Safe transport, Handling, and Storage

This equipment is designed to be as safe as possible under all foreseeable conditions of transport, handling, and storage. Be certain to switch the equipment off, unplug it, and let it cool before handling any parts that become hot during operation, and before storing. When handling your machinery, be aware of the following weights and dimensions:

R-1824-240 (Head Only) 43 lbs (19.5 kg) 26" x 35" x 8" (66 x 90 x 20 cm)

R-18-240 (Head Only) 35 lbs (16 kg) 26" x 29" x 7" (66 x 74 x 18 cm)

RA-18-240 (Head Only) 64 lbs (29 kg) 29" x 26" x 15" (74 x 66 x 38 cm)

RA-1824-240 (Head Only) 74 lbs (35.5 kg) 35" x 29" x 15" (89 x 74 x 38 cm)

SH-STAND-WS Standard Stand for Manual Flash 22 lbs (10 kg) 37" x 7" x 3" (94 x 18 x 8 cm)

SHHD-STAND-M Heavy Duty Stand for Manual Flash 42 lbs (19kg) 30" x 14" x 7" (76 x 35.5 x 18 cm)

SH-LEGS-AF Standard Stand for AutoFlash 15 lbs (7 kg) 37" x 7" x 3" (94 x 18 x 8 cm)

SHHD-STAND Heavy Duty Stand for AutoFlash 39 lbs (18 kg) 30" x 15" x 11" (76 x 38 x 28 cm)

— Safety Information

- The operator should read and understand the instruction manual before operating this equipment. Store this manual and safety information near the equipment for easy access to operators.
- VASTEX flash units are intended for the curing of non-flammable inks on screen printed materials. Do not use for any other purpose unless authorized by Vastex International, Inc. Use of this equipment for any other purpose can be dangerous and may cause damage to this equipment, voiding the warranty.
- It is recommended that the area around this equipment be designated as a work area and only authorized employees are allowed in this area.
- Children and pets must be kept clear from the work area.
- Do Not place any objects on top of the heater or control box; surfaces are hot.
- Never leave equipment unattended.
- DO NOT operate any flash units with any cover or guard removed.
- Do Not operate if the power cord or heater face is damaged.
- Operator must be familiar with the controls of the flash unit before operating.
- Before starting production, check that all covers and guards are in place, no material has been left on the flash unit, and the work area is clear of obstructions.
- Make certain when turning on the heater that it is not positioned over any flammable material, including the printer pallet. If heater is allowed to dwell over pallet for extended periods of time it will damage the pallet surface.
- Always turn off power at the main disconnect (breaker) at the end of production.
- Do Not remove any cover or guard until power at the main disconnect is switched off and locked out. No unauthorized persons are to be allowed inside the control boxes.
- Turn off and lock out power at the main disconnect before cleaning and maintenance.
- Only qualified technicians should be allowed to make repairs on VASTEX Flash Units.
- **Noise and vibration:** These units do not produce noise exceeding 70 dB(A).

Warning

- Heat Control and/or power switch should be switched off before plugging and/or unplugging the power cord.
- RedFlash Units are equipped with a cooling fan. Fan operates when heat control is turned on. Do Not use flash unit if cooling fan is not operating. Replace fan immediately if NOT operational. See the controls section for cooling fan replacement and ordering information.

— Electrical Components and Info

18" x 18" RedFlash

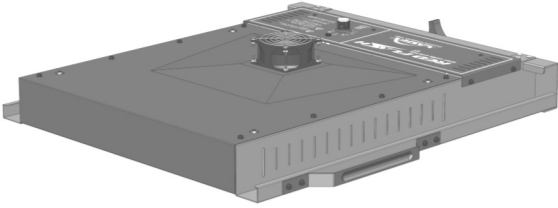

R-18-240: 240 Volts, 11 Amps, 50/60 Hz, 2600 Watts.
Supplied with a required NEMA 6-15P Plug.

R-18-240-HO: 240 Volts, 16.5 Amps, 50/60 Hz, 3500 Watts.
Supplied with a required NEMA 6-20P Plug.

Requires a dedicated outlet on a properly rated 20 amp circuit.

18" x 24" RedFlash

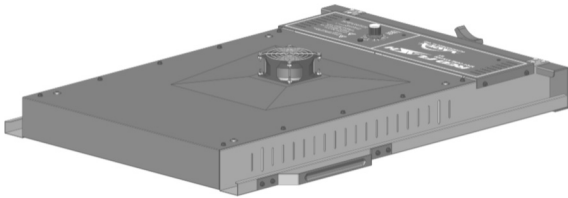

R-1824-240: 240 Volts, 16.5 Amps, 50/60 Hz, 3500 Watts.
Supplied with a required NEMA 6-20P Plug.

Requires a dedicated outlet on a properly rated 20 amp circuit.

18" x 18" AirFlash

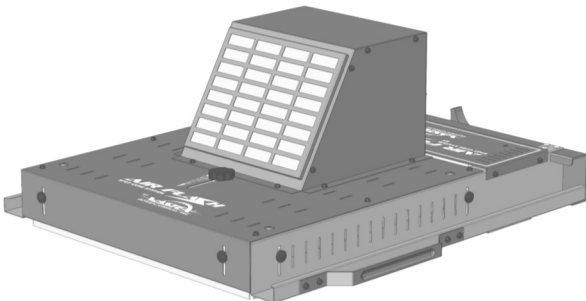

RA-18-240: 240 volts, 17.5 Amps, 50/60 Hz 3500 Watts
Supplied with a required NEMA 6-20P Plug.

Requires a dedicated outlet on a properly rated 20 amp circuit.

18" x 24" AirFlash

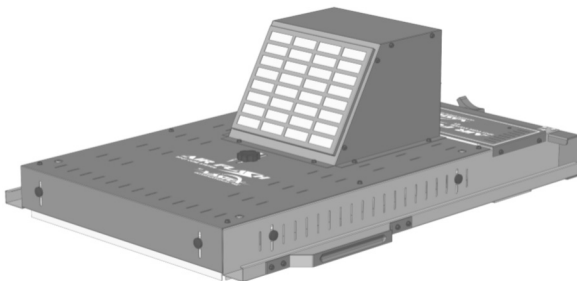

RA-1824: 240 Volts, 22 Amps, 50/60 Hz, 4300 Watts
NEMA 6-30P Plug sold separately.

Requires a dedicated outlet on a properly rated 30 amp circuit.

Do not modify the power cord or plug. If unsure of your power source, consult a qualified electrician.

— Assembly (SHHD-STAND)

Contents of Heavy Duty Stand box for Manual

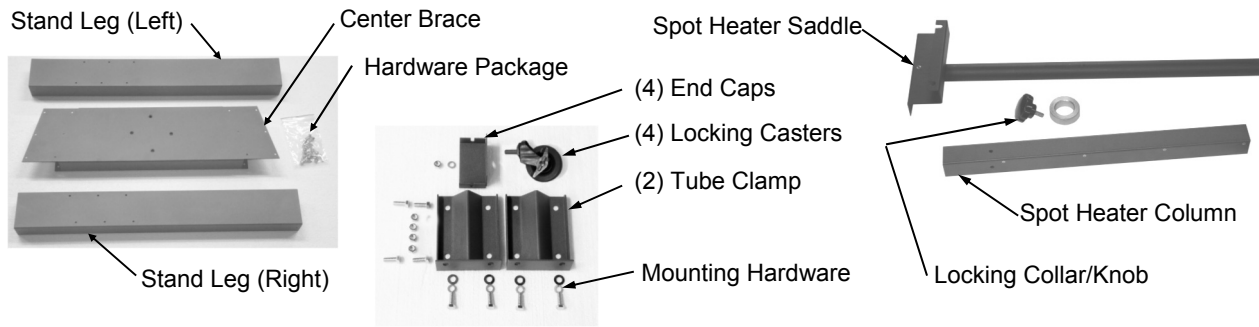

1) Remove all parts from the box they were shipped in.

2) Place Legs and Middle on floor as shown. Note hole in left leg for orientation.

3) Install and **Tighten**
 -(16) #14 Sheet Metal Screws
 Use 3/8 Socket or Wrench

4) Install and **Tighten (4x)**

-Attach Wheel and Stud to each bracket with 1/2" nut.
 Use 3/4 Socket or Wrench

-Attach Wheel bracket to Stand Legs using (2) #14 Sheet Metal Screws
 Use 3/8 Socket or Wrench

5) Install and **Leave Loose**

-(4) 3/8-16 Bolts, lock washers, and nuts

6) Install and **Leave Loose**

-(4) 3/8-16 Bolts, washers, and lock washers

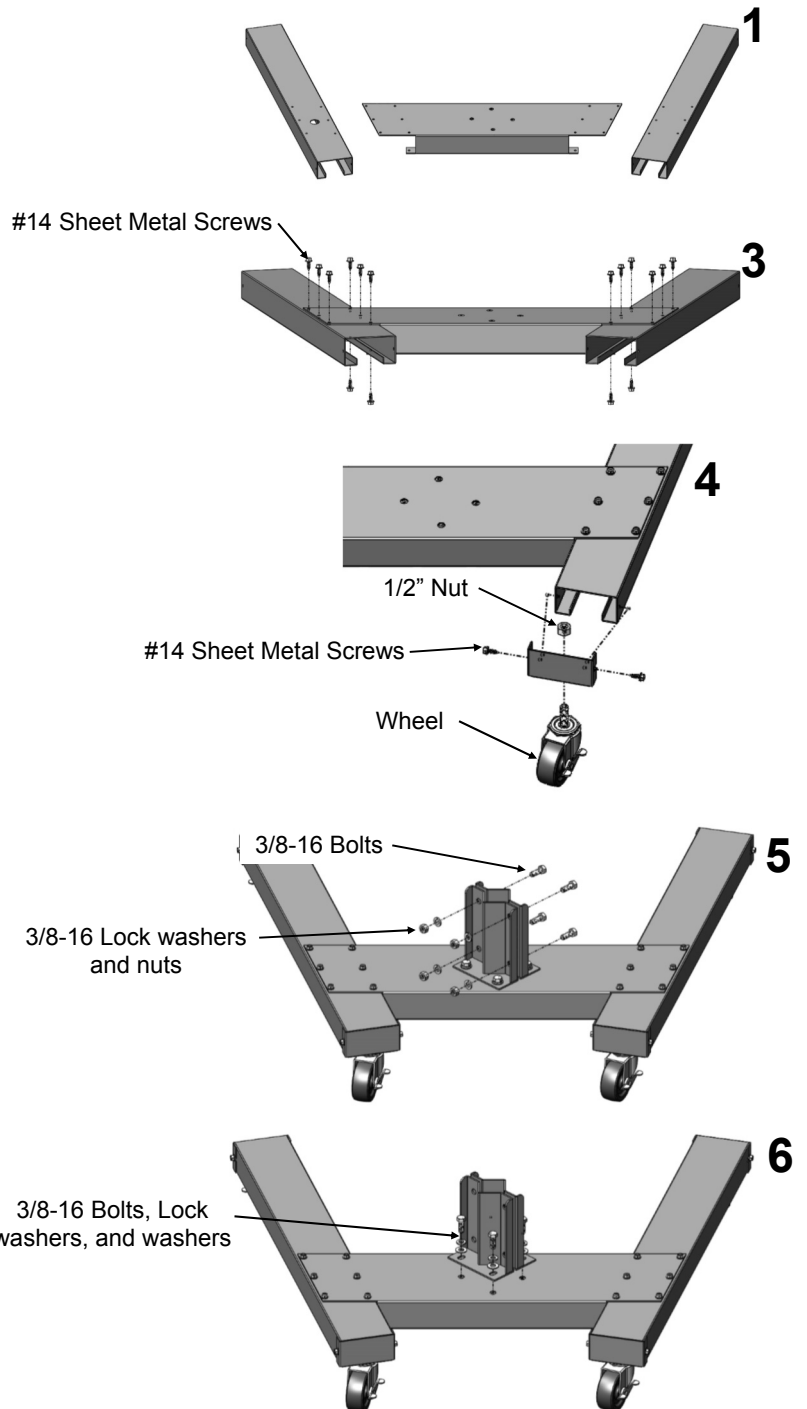

— Assembly (SH-STAND)

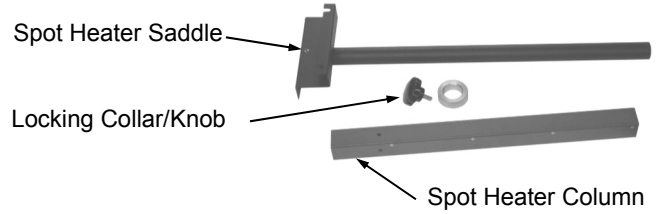
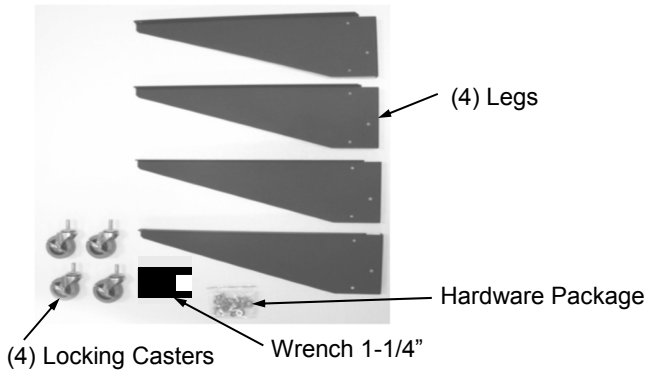

- 1) Install and Leave Loose**
- (2) Legs
 - (2) 1/4"-20 Bolts and Nuts
- Note Orientation of legs

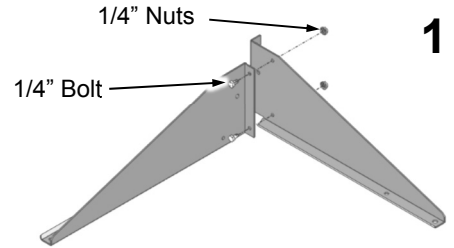

- 2) Install and Leave Loose**
- (1) Leg
 - (2) 1/4"-20 Bolts and Nuts

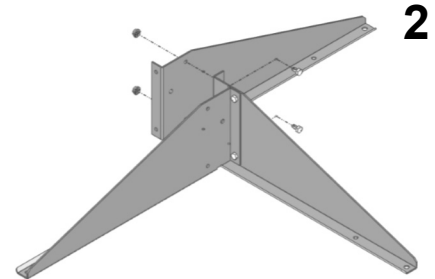

- 3) Install and Leave Loose**
- (1) Leg
 - (4) 1/4"-20 Bolts and Nuts

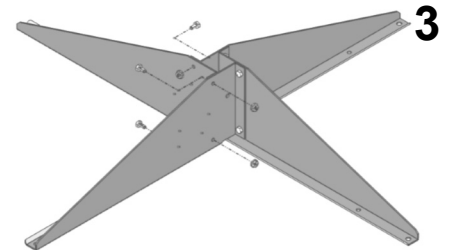

- 4) Install and Tighten**
- (4) Wheels with studs
 - (4) 3/8"-16 Nuts
- Use 9/16 Socket or Wrench

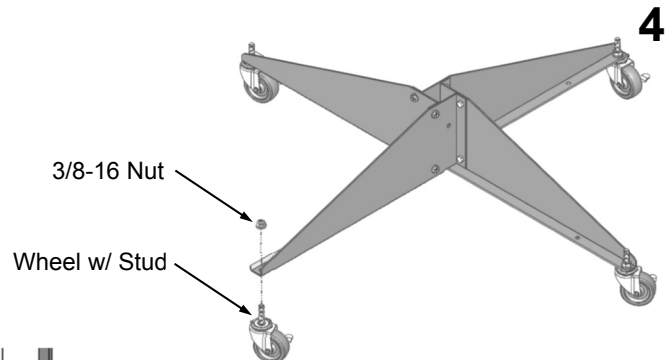

NOTE:

- Orientation of stand legs shown on right
- Top View shown without hardware

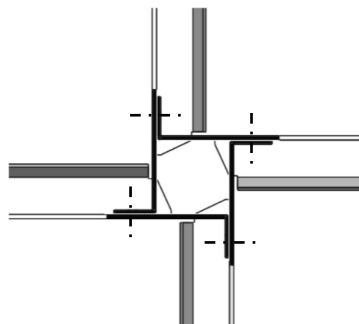

— Assembly

SH-STAND

1a) Install Spot Heater Column into stand as shown. Note orientation of tube. Rivets should not be clamped into stand on bottom.

1b) Install and **tighten**

- (1) 1/4"-20 x 2-1/4" Bolt

- (1) 1/4-20 Serrated Nut

Tighten Using 7/16" or 11mm Wrench

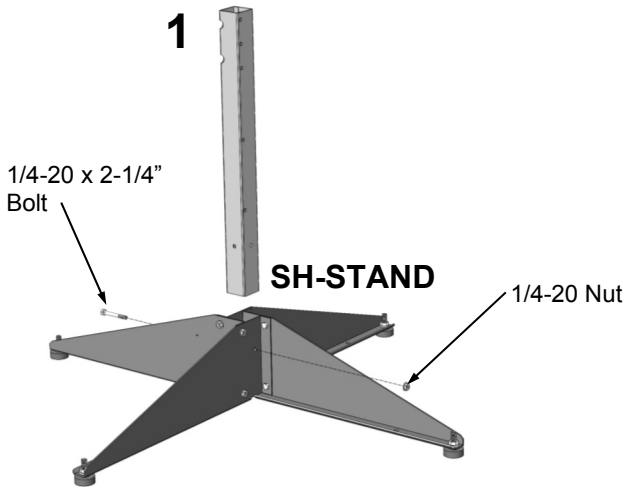

SHHD-STAND

1a) Install Spot Heater Column into stand as shown. Note orientation of tube. Rivets should not be clamped into stand on bottom.

1b) Tighten bolts installed in stand assembly procedure.

- (8) 3/8" Bolts, lock washers, and nuts

Tighten using a 9/16" or 15mm Wrench

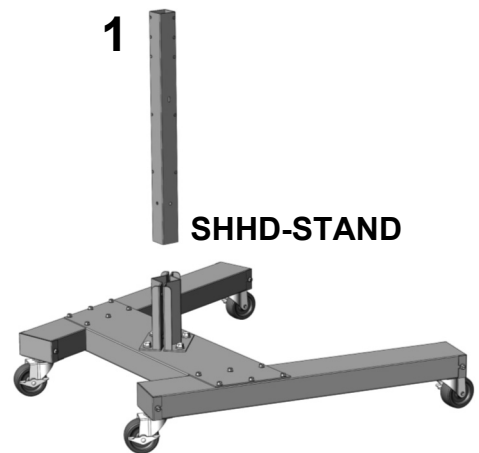

2) Install Saddle, Tube Clamp, and Knob into flash stand as shown. Tighten Knob to set height.

3) Loosen (2) 3/8-16 bolts about 1/8" and install Flash Head onto saddle.

4) Tighten both bolts once Flash Head is seated completely.

Tighten using 9/16 or 15mm wrench

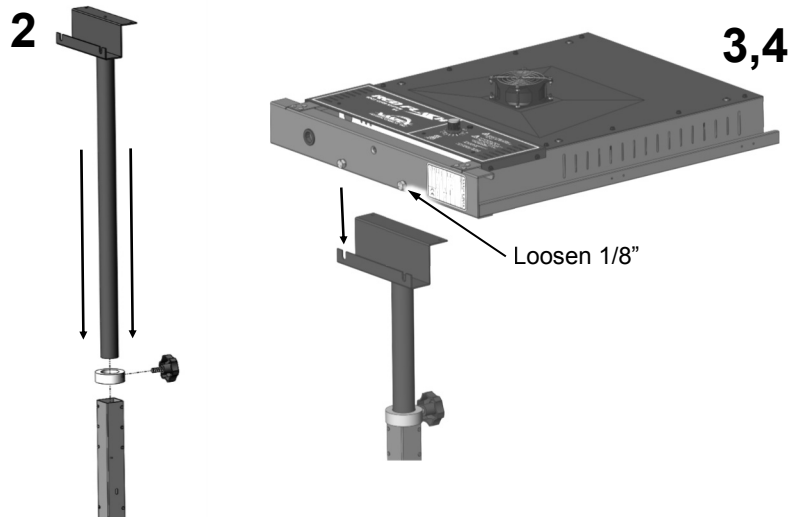

5) Install Knob as shown on right. Knob is used to level the Flash Head.

6) Install Flash Handles on each side.

- (2) Flash Handles (1 each side)

- (8) #8 Sheet metal screws.

Tighten using 1/4" nut driver or flat blade screw driver

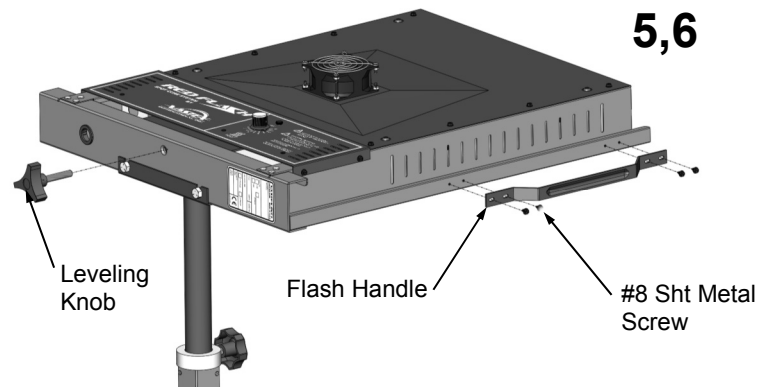

Controls

Heating Operation

Your Vastex Flash will effectively dry all types of plastisols and thermoset inks. Set the control to position 5 and a distance of 2-4" from the face of the heater to the surface of the garment. The normal dwell time under the heater is the time you spend printing another garment. Nevertheless, 6-10 seconds is the time needed to effectively "skin-over" the ink deposit. Adjustments to the temperature control and distance may have to be made for the specific application. You should not try to final cure with a spot heater due to the fact that matching the precise time in heat of a conveyor will be difficult and can cause damage to your pallet. *(Caution should be taken when operating the flash unit. The heater surface is very hot. Never leave the flash unit on and left unattended.)*

Heat Controller

The control has positions LO-2-3-4-5-6 and HI. The controller turns the power to the heater on and off to vary the temperature. The higher the number on the controller the longer the on cycle and shorter the off cycle is. The "HI" position keeps the power on constantly. The light indicates controller is on.

Heat On

This RED light is wired to the controller. It will illuminate when the control is turned on, even if the controller has failed.

Cooling Fan

RedFlash Units are equipped with a cooling fan. Fan operates when heat control is turned on. Do Not use flash unit if cooling fan is not operating. Replace fan immediately if NOT operational. Order p/n 04-02-052 replacement fan from Vastex International Inc.

-Shut Down Procedure:

Turn heat control to "LO" (RedFlash) or "OFF"(AirFlash) for 10 minutes. Turn off heat control and (airflash only) main power switch. Unplug or shut off breaker at the end of every shift.

Heater Height Adjustment

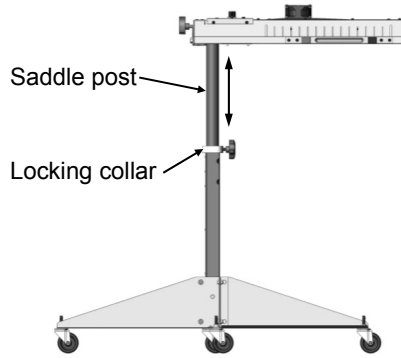

To raise and lower the flash head, grasp the saddle post firmly, loosen the locking collar knob, adjust the height and retighten the knob.

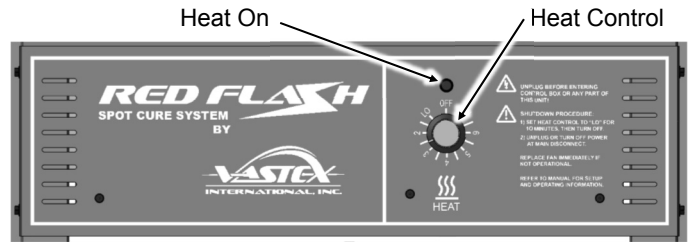

RedFlash control panel

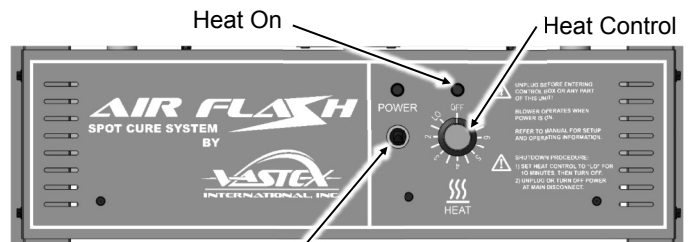

Main Power Switch

AirFlash control panel

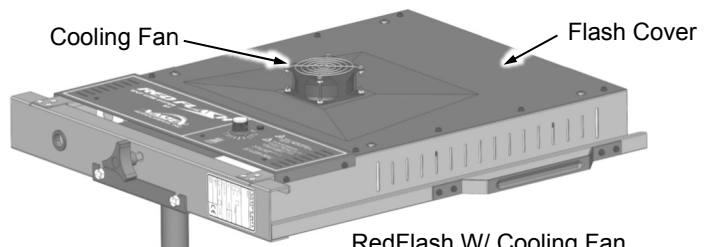

RedFlash W/ Cooling Fan

Controls (AirFlash)

Air Controls (AirFlash Only)

The Airflash blower runs when the main power switch is on. The AirFlash air controls are operated using a single knob. Loosen and slide the air flow adjust knob to control the air flow through the heater. Adjust from "full on" to "off" (bypass) as needed. The air is also used to cool the flash unit; replace blower when necessary.

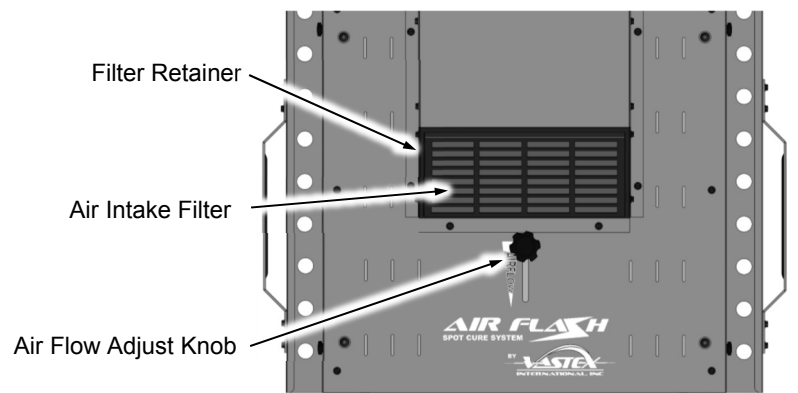

Clean the air intake filter regularly. Slide the filter retainer up to access the filter.

— Troubleshooting

Safe maintenance and troubleshooting:

- Before beginning any maintenance or troubleshooting on your equipment, unplug your machine from its electrical outlet.
- The heat control and/or power switch should be switched off before plugging and/or unplugging the power cord.
- Allow time for the equipment to cool before attempting any service on the heater
- Do not remove any panels with the equipment powered on; any such service must be performed by qualified personnel only.
- If your machine appears to be operating abnormally and the troubleshooting charts below do not resolve your problem, shut your unit off, unplug it, and contact Vastex for further assistance.

In the event of a malfunction or breakdown:

Shut off power to the equipment and unplug from electrical outlet. Then, following the troubleshooting charts below. If this does not resolve your issue, please contact Vastex for support.

Symptom	Possible Cause	Solution
No Heat	Machine unplugged? Faulty temperature controller Faulty heater	Plug into appropriate outlet Contact Vastex for assistance Contact Vastex for assistance
Fan/blower not running	Faulty fan/blower	Replace fan/blower
Heat on, cannot be controlled	Faulty temperature controller	Contact Vastex for assistance

Cooling Fan Replacement:

- 1) Unplug or switch off power at the main disconnect.
- 2) Remove plug from cooling fan.
- 3) Remove Flash Cover mounting screws.
- 4) Remove failed fan, install new fan, airflow direction is down.
- 5) Transfer ground wire, warning label plate and guard onto new fan.
- 6) Reverse step 1-3 to complete reassemble.

— Maintenance

Your equipment is designed to provide a long service life with little maintenance required. Before using your machine at the beginning of each work shift, check that its fan is working. Do not operate if the fan/blower has failed.

On AirFlash models:

- Clean the air filter regularly (see page 8).

On all models:

- Periodically check the heater face and power cord to ensure that neither has become damaged.
- Periodically verify correct functioning of all controls.

Vastex Warranty

Doc#01-00-005D Revised 2/20/2018

(1.) Vastex, hereinafter referred to as "seller" warrants only to its original "purchaser", who holds a copy of the original invoice and is the original end user of the equipment in question, its new equipment against manufacturer defects in materials or workmanship on a pro-rated basis. Warranty period begins from date of shipment to the buyer and will only apply to customers paid in full. Warranty periods are as follows: one (1) year for E-1000, three (3) years for all other complete machines (including F-Flash), fifteen (15) years for infrared heaters (excluding F-Flash) installed by Vastex in a new dryer, three (3) years for replacement infrared heaters, and one (1) year for replacement parts. Rubber blankets, light bulbs and glass on exposure units are particularly subject to wear while in use. Wear is not covered by this warranty but as stated above only manufacturers defects are covered. All sales made through Vastex dealers must be certified by that dealer before a warranty replacement is issued. All equipment is thoroughly tested and inspected before packaging. This warranty does not cover minor cosmetic damages that occur during shipment that do not affect the functionality of the equipment.

(2.) This warranty is expressly contingent upon the buyer delivering to seller, at the address below, with all transportation charges prepaid, the part or parts claimed to be defective within the above mentioned warranty periods stated in paragraph one. The defective part or parts will be repaired or replaced at the discretion of Vastex International, Inc. If the equipment in question is less than one (1) year old, it will be shipped to the customer at no charge, with an RGA issued by Vastex for the defective part. The defective part must be shipped back to Vastex freight prepaid within 30 days or the account will be billed. If the equipment is more than a year old, the part will be shipped after we receive the defective part. If it's necessary to expedite the movement of parts and to minimize down time to the buyer, the replacement part shall be supplied on a C.O.D. basis. If testing and analysis of said part by the seller or its supplier discloses that said part is defective, the cost of said part will be refunded to the buyer on a prorated basis.

(3.) Except as otherwise provided herein, the equipment is being sold "as-is". Final determination of the suitability of the equipment for the use contemplated by the buyer, is the sole responsibility of buyer, and seller shall have no responsibility in connection with the suitability.

(4.) All warranties implied by law, including the implied warranties of merchantability and fitness are hereby limited to manufacturer defects in materials or workmanship during the warranty period stated in paragraph one. The express warranty and remedies contained herein and such implied limited warranties are made solely to the sole warranties and remedies and are in lieu of all other warranties, guarantees, agreements, and other liabilities, whether express or implied, and all other remedies for breach of warranty or any other liability of seller, in no event shall seller be liable for consequential damages.

No person, agent, distributor, or service representative is authorized to change, modify or extend the terms hereof in any manner whatsoever.

These terms and conditions are an essential part of the transaction between the parties and constitute the entire agreement between them with respect to the same.

Some states do not allow limitation on how long an implied warranty lasts of the exclusion or limitation of incidental, or consequential damages, so the above limitation may not apply to you.

This warranty gives you specific legal rights, and you may also have other rights which vary from state to state.

Infrared heaters are the only replacement parts covered for a period of (3) years from date of shipment and contingent to receipt of payment in full.

Electrical components cannot be returned once installed unless proven defective.

Please refer to doc. 01-00-015 for specific terms and conditions of sale and the limited warranty.

Please refer to doc. 01-00-017 for V-2000HD printer warranty.

Updates: V1000 to 3 year warranty 01/09/12, Heater warranty to 15 years 01/02/2012.

TERMS AND CONDITIONS OF SALE AND LIMITED WARRANTY Doc.#01-00-015

- Buyer's order will constitute an offer in accordance with the terms hereof and such offer, upon acknowledgment of Seller, will constitute the agreement between Buyer and Seller. Buyer's order after such acknowledgment by Seller will not be subject to cancellation, change or reduction in amount, or suspension by Buyer of deliveries, unless prior to such action Buyer has obtained Seller's written consent. Notwithstanding anything to the contrary in Buyer's Purchase Order or other communications, the parties agree to be bound by these Terms and Conditions. Acceptance of the product by the Buyer shall be deemed to constitute unconditional acceptance of these Terms and Conditions.
- Any of these terms, conditions and provisions of Buyer's order which are inconsistent with Seller's acknowledgment and these Terms and Conditions of Sale shall not be binding on the Seller and shall be considered not applicable to any sale so made. No waiver, alteration or modification of any of the provisions on either side of the document shall be binding upon Seller unless agreed to in writing by Seller.
- (a) All prices are F.O.B. Seller's Plant and method of delivery and routing shall be at Seller's discretion, unless specifically otherwise stated herein. Notwithstanding any agreement to pay freight, delivery of products purchased hereunder to a common carrier or licensed trucker shall constitute delivery to Buyer and be determinative of the date and time of shipment and all risk of loss or damage in transit shall be borne by Buyer. If the Buyer fails to accept the goods from the common carrier or licensed trucker, the Seller shall be entitled to claim payment from the Buyer. Seller shall arrange for storage, the risk and the cost, including insurance costs, to be borne by the Buyer (and Buyer agrees to pay such amounts upon demand) except if the failure to accept delivery is due to any of the exceptions noted in Paragraph 4.
(b) Terms of payment shall be as stated on invoice.
- It is understood that deliveries will be made in accordance with Seller's regular production schedule. Every reasonable effort will be made to meet the Buyer's required delivery dates but Seller will not be liable for damages or be deemed to be in default by reason of any failure to deliver or delay in delivery due to any preference, priority, allocation or allotment order issued by the Government, whether Federal, State or local, or causes beyond its control including but not limited to, Acts of God or a public enemy, acts of Government, fires, floods, epidemics, quarantine restrictions, strikes, lockouts, freight embargoes, severe weather, unavailability of materials or shipping space, delays of carriers or suppliers or delays of any subcontractors. Should delay in delivery be caused by any of the circumstances mentioned in this paragraph, such extension of the delivery period shall be granted as is reasonable under the circumstances of the case. Should delay be caused by an event not specifically mentioned in this paragraph, damages will be limited to cancellation of the purchase order without penalty, and refund of any monies deposited or prepaid on the purchase order with no liability for any consequential or incidental damages.
- Seller reserves the right to increase the prices prior to Seller's acceptance of order and/or after expiration of any price quoted by Seller.
- Unless otherwise stated in writing, Seller's prices do not include sales, excise, value-added or other taxes. Consequently, in addition to the price specified herein, the amount of any present or future sales, use, excise, value-added or other tax applicable to the manufacture, sale, purchase or use of the products hereunder shall be paid by Buyer, or in lieu thereof, Buyer shall provide Seller with a valid tax exemption certificate acceptable to the taxing authorities.
- Seller reserves the right, at any time, to revoke any credit extended to Buyer because of Buyer's failure to pay for any products when due or for any other reason deemed good and sufficient by Seller and in such event, all subsequent shipments shall be paid for prior to at delivery at Seller's option.
- (a) SELLER'S LIABILITY SHALL BE LIMITED TO SELLER'S STATED SELLING PRICE PER UNIT OF ANY DEFECTIVE GOODS AND SHALL IN NO EVENT INCLUDE BUYER'S MANUFACTURING COSTS, LOST PROFITS, GOODWILL, OR ANY OTHER SPECIAL, INDIRECT, INCIDENTAL OR CONSEQUENTIAL DAMAGES, ARISING OUT OF THE AGREEMENT, THIS CONTRACT, THE SALE OF THE PRODUCTS TO THE BUYER OR THE USE OR THE PERFORMANCE OF THE PRODUCTS. Seller may at its discretion repair, replace or give the Buyer credit (pro-rated) for such defective products.
(b) Notwithstanding anything herein to the contrary, Seller shall have no liability for alleged defects with the products which are not specified in written notice from the Buyer to the Seller within thirty-six (36) months from the date of shipment of machines. Seller shall pass to Buyer any warranty received by Seller from the manufacturer of Limited Life Components, which in most cases is 12 to 18 months.
(c) Seller shall have no liability under this Limited Warranty unless Buyer has paid in full for the products. Further, this Limited Warranty is expressly contingent on Buyer's delivery to Seller, all costs prepaid, the defective part(s) within thirty-six (36) months of shipment to Buyer, together with a written statement specifying the alleged defect(s). Any replacement part(s) shall be shipped to Buyer on a C.O.D. basis.
(d) SELLER SPECIFICALLY EXCLUDES ALL WARRANTIES, EXPRESSED, IMPLIED OR OTHERWISE, EXCEPT AS STATED EXPLICITLY IN THESE TERMS AND CONDITIONS OF SALE. SELLER DISCLAIMS THE WARRANTY OF MERCHANTABILITY AND FITNESS FOR A PARTICULAR PURPOSE.
- The remedies herein reserved by Seller shall be cumulative and in addition to any other legal remedies. No waiver of a breach of any portion of this contract shall constitute a waiver of continuing or future breach of such provision or of any other provisions hereof.
- These Terms and Conditions constitute the entire agreement of the parties. No amendments, changes, revisions or discharges hereof in whole or in part shall have any force or effect unless set forth in writing and signed by the parties hereto. This contract shall not be assignable by Buyer voluntarily by operation of law or otherwise without Seller's written consent.
- This contract shall be governed and shall be construed according to the domestic laws of the Commonwealth of Pennsylvania.
- Anything herein to the contrary notwithstanding, any action for alleged breach by Seller of the contract between the parties, including but not limited to any action for breach of the warranties herein set forth, shall be barred unless commenced by Buyer within one (1) year from the date such cause of action accrued.
- This agreement shall inure to the benefit of and be binding upon the parties hereto, their respective successors and permitted assigns.
- All notices required by this contract to be given by either party shall be sent in writing or by facsimile and shall be addressed to the last known address of such other party. Notices shall be deemed to have been received on the fifth business day following deposit in the mail.

VASTEX
INTERNATIONAL

7 EMERY ST
BETHLEHEM, PA. 18015 USA

EC DECLARATION OF CONFORMITY

MANUFACTURER

Company name: Vastex International Inc
Full address: 7 Emery Street
Postal code: 18015-1982
Place: Bethlehem, PA
Country: United States of America

EUROPEAN AUTHORISED REPRESENTATIVE

Which is established in the European Union and has access to the Technical File

Company name: Certification Experts
Full address: Stationsplein 30
Postal code: 1382 AD
Place: Weesp
Country: The Netherlands

DESCRIPTION AND IDENTIFICATION OF THE MACHINERY

Generic name: Flash Cure Units
Function: Spot Heating Unit
Model: [F-100] – XX [R1824] – XX
[F-1000] – XX [RA-18] – XX
[R18] – XX [RA-1824] – XX
Serial number: VTX-xxxxx
Commercial name: F100/F1000 and
RedFlash/AirFlash

COMPLIANCE

The manufacturer declares that the above mentioned machinery fulfills all relevant provisions of

Machinery Directive 2006/42/EC
Low Voltage Directive 2014/35/EU
EMC Directive 2014/30/EU

*In conjunction with the following harmonised standards
and where appropriate other technical standards and specifications
for the risk assessment*

EN-ISO 12100:2010

for the design and manufacture

EN-IEC 60204-1:2006; EN 574:1997+A1:2008;
NEN-EN 349:1994+A1:2008; NEN-EN 953:1998+A1:2009; NEN-EN-IEC 61000-6-2:2005;
NEN-EN-IEC 61000-6-4:2007/A1:2011

Certifications Experts B.V. in Weesp the Netherlands, has determined the presumption of conformity of the
above mentioned installation with the applicable Directives and standards

Place: Weesp Name: Rebecca Brust
The Netherlands Function: Operation and Certification Manager

Date: 1 May 2018

Signature:

